



# F9.60 Flow Monitor and Transmitter

## INSTRUCTION MANUAL

EN 10-11

### Table of Contents

<b>1. Introduction.....</b>	<b>3</b>
Safety Instructions.....	3
Unpacking.....	3
<b>2. Description.....</b>	<b>4</b>
Design.....	4
Technical Features.....	4
Connection to FlowX3 Sensors.....	5
<b>3. Specifications.....</b>	<b>5</b>
Technical Data.....	5
Dimensions.....	6
<b>4. Installation.....</b>	<b>7</b>
Location.....	7
Wiring.....	8
<b>5. Operational Overview.....</b>	<b>11</b>
Keypad Functions.....	11
General Operation Flowchart.....	11
<b>6. View Level.....</b>	<b>13</b>
<b>7. Menu Directory Level.....</b>	<b>14</b>
7.1. Free access (no password required).....	14
7.2. Password protected access.....	14

<b>8. Menu and Edit Level.....</b>	<b>15</b>
<b>8.1. Calibration Menu.....</b>	<b>15</b>
8.1.1. Unit.....	15
8.1.2. K-Factor.....	16
8.1.3. Size.....	16
<b>8.2. Output Menu.....</b>	<b>17</b>
8.2.1. 4 – 20mA Output.....	17
8.2.2. O.C. Output (OPT).....	18
8.2.2.1. O.C. Output (OPT): MIN mode.....	18
8.2.2.2. O.C. Output (OPT): MAX mode.....	19
8.2.2.3. O.C. Output (OPT): PULSE mode.....	20
<b>8.3. Simulation Menu.....</b>	<b>23</b>
8.3.1. Test 4 – 20mA Loop.....	23
8.3.2. Test O.C. Output (OPT).....	24
8.3.3. Test R1 Output (OUT1).....	24
<b>8.4. Options Menu.....</b>	<b>25</b>
8.4.1. Contrast.....	25
8.4.2. Filter.....	26
8.4.3. Flow Decimal Point.....	26
8.4.4. Total Decimal Point.....	27
8.4.5. Loop Adjust 4mA.....	27
8.4.6. Loop Adjust 12mA.....	28
8.4.7. Loop Adjust 20mA.....	28
8.4.8. Menu PWD.....	28
8.4.9. Restot PWD.....	29
8.4.10. Language.....	29
8.4.11. K-Factor Calculate.....	30
<b>9. Troubleshooting.....</b>	<b>31</b>
9.1. Display messages.....	31
<b>10.K-Factor Tables.....</b>	<b>32</b>
<b>11.Ordering Data.....</b>	<b>39</b>

## 1. Introduction



**CAUTION**

### 1.1. Safety Instructions

#### General Statements

- ❑ Do not install and service the instrument without following the Instruction Manual.
- ❑ This unit is designed to be connected to other instruments which can be hazardous if used improperly. Read and follow all associated instrument manuals before using with this instrument.
- ❑ Unit installation and wiring connections should only be performed by qualified staff.
- ❑ Do not modify product construction.

#### Installation and Commissioning Statements

- ❑ Remove power to the instrument before wiring input and output connections.
- ❑ Do not exceed maximum specifications using the instrument.
- ❑ To clean the unit, use only chemical compatible products.

### 1.2. Unpacking

Please verify that the product is complete and without any damage. The following items must be included:

- F9.60 Electromagnetic Flow Sensor
- Instruction Manual for F9.60M Flow Sensor

## 2. Description

### 2.1. Design

The FLOWX3 NEW F9.60M Insertion Magmeter is suitable to measure flowrate in both metal and thermoplastic pipelines.

No moving mechanical parts and the high quality materials allow the measurement of liquids where suspended solids can be present or of abrasive liquids as long as they are conductive and homogeneous.

The sensor can be assembled into the standard FLS fitting range so it is perfectly interchangeable with the paddlewheel sensors. The new design allows an accurate flow measurement over a wide dynamic range in pipe sizes from DN15 (0.5") to DN600 (24").

The FLS FlowX3 F9.60 offer an indication and a 4...20 mA signal for long distance transmission and it also provides one programmable open collector output and two relay outputs. Self explaining calibration menus allow a customized setup of all measuring parameters and the state of the art electronic design ensures long-term reliable and stable signals.

### 2.2. Technical Features

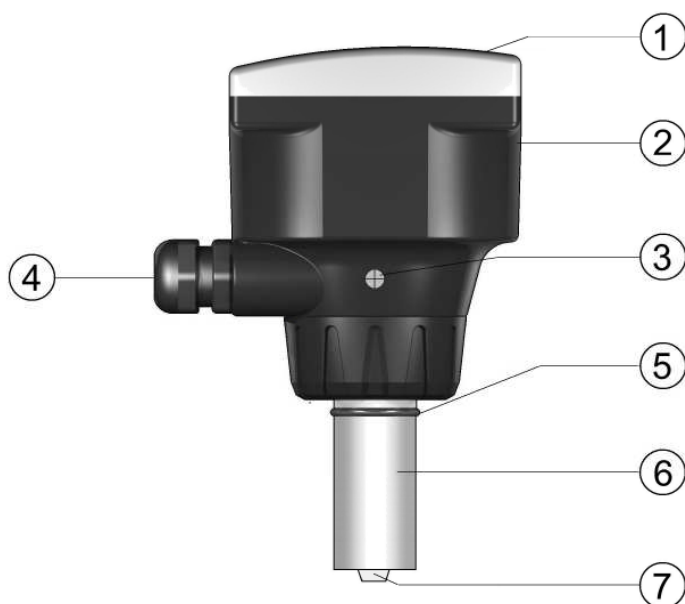

- 1) Electronic box
- 2) PC box
- 3) External Earth Ground Terminal
- 4) Cable Gland
- 5) O-Ring (EPDM or FPM)
- 6) Sensor body 316L SS or CuNi
- 7) PVDF or PEEK reading head

## 2.3. Operating Principle

If an electrical conductor is caused to move in a magnetic field, such movement induces a voltage in the conductor ( Faraday's law ). The magnetic coil in the body of the instrument generates a magnetic field perpendicular to the flow direction. The magnetic field and the velocity induce a voltage between the electrodes. The voltage is directly proportional to the flow velocity.

## 3. Specifications

### General

- Pipe Size Range: DN15 to DN600 (0.5" to 24"). Please refer to Installation Fitting section for more details.
- Flow Rate Range: 0.05 to 8 m/s (0.15 to 25 ft/s).
- Full Scale Range : 5 m/s (16,4 ft/s) standard (others available on request).
- Linearity:  $\pm 1\%$  of reading + 1 cm/s
- Repeatability:  $\pm 0.5\%$  of reading
- Enclosure: IP65
- Materials:
  - Case: PC/PVC
  - Gasket: EPDM
- Display:
  - 3 line LCD: 2 x 12 alphanumeric lines + 1 icon line
  - Update rate: 1 second
  - User adjustable with 5 levels
- Wetted Materials:
  - Sensor body: 316L SS/PVDF, CuNi/PVDF or 316L SS/PEEK
  - O-rings: EPDM or FPM
  - Electrodes: 316L SS or CuNi

### Electrical

- Power Supply:
  - 12-24 VDC + 10% regulated (reverse polarity and short circuit protected)
  - Maximum current consumption: 300 mA
  - Protective earth:  $< 10 \Omega$
- Current output:
  - 4 – 20 mA, isolated, fully adjustable and reversible
  - Max. loop impedance:  $600 \Omega @ 24 \text{ VDC}$
  - Frequency output:
- Open Collector output:
  - User selectable as MIN alarm, MAX alarm, Pulse Out, Off
  - Optically isolated, 50 mA MAX sink, 24 VDC MAX pull-up voltage
  - Max pulse/min: 300
  - Hysteresis: User selectable
- Relay output:
  - User selectable as MIN alarm, MAX alarm, Pulse Out, Off
  - Mechanical SPDT contact
  - Max pulse/min: 180
  - Hysteresis: User selectable

## Environmental

- Storage Temperature: -10°C to +60°C (14°F to 140°F)
- Ambient Temperature: 0°C to +60°C (32°F to 140°F)
- Relative Humidity: 0 to 95% (non-condensing)
- Fluid conditions:
  - homogeneous liquids, pastes or slurries, also with solid content
  - Min Electrical Conductivity: 20  $\mu$ S
  - Temperature: -10°C to 60°C (14°F to 140°F) with PVDF reading head
  - Temperature: -10°C to 150°C (14°F to 302°F) with PEEK reading head
- Max. operating pressure:
  - 16 bar @ 25°C (232 psi @ 77°F)
  - 8.6 bar @ 60°C (124 psi @ 140°F)

## Standards & Approvals

- Manufactured under ISO 9001 (Quality)
- Manufactured under ISO 14001 (Environmental Management)
- CE

## 3.2. Dimensions

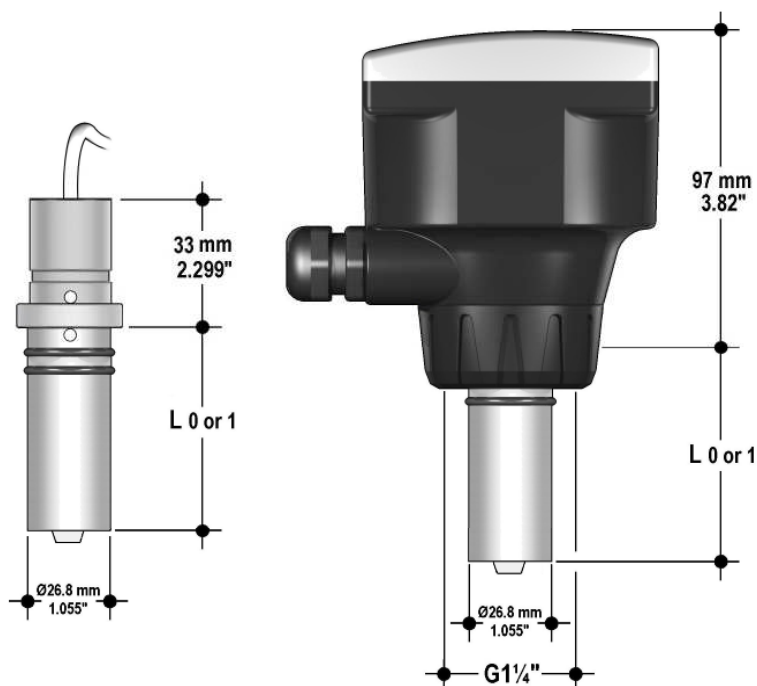

## 4. Installation

### 4.1. Location

Different pipe configurations and obstacles in the flow line such as valves, elbows, pipe bends and strainers create variations on the flow profile.

Whenever possible follow the EN ISO 5167-1 installation recommendations to locate the sensor.

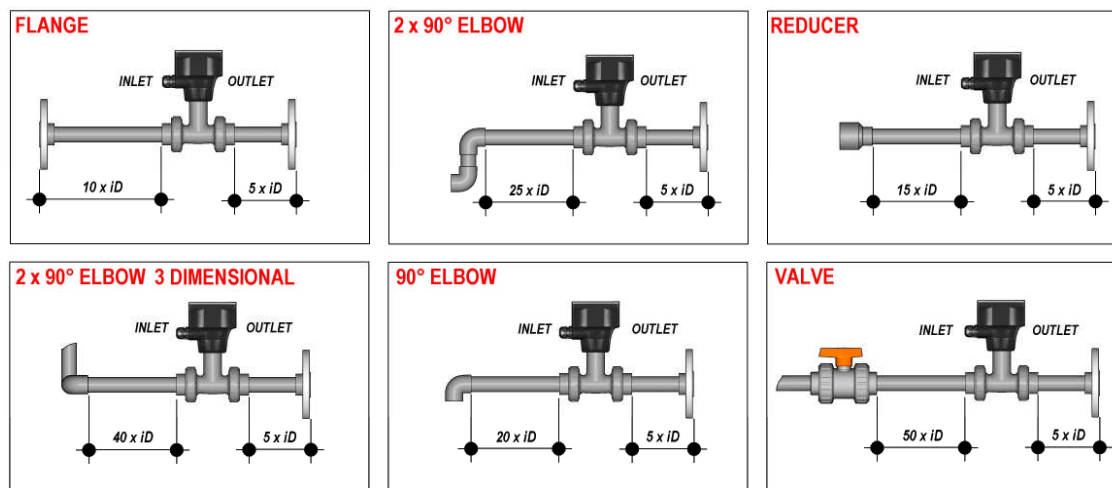

Always maximize distance between flow sensor and pump.

### 4.2. Mounting Position

The following configurations ensure that the pipe is always full: for a correct measurement the sensor can NOT be exposed to air bubbles at any time.

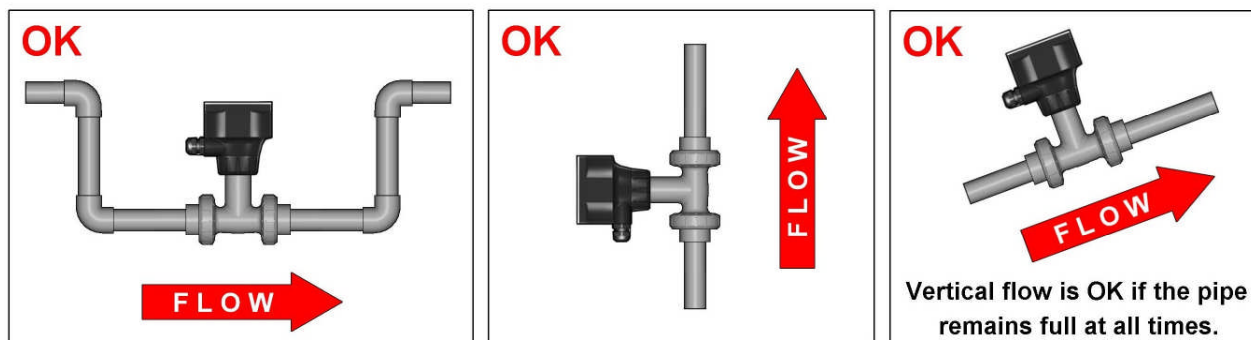

Avoid the following situations unless you are absolutely sure the sensor is not exposed to air bubbles.

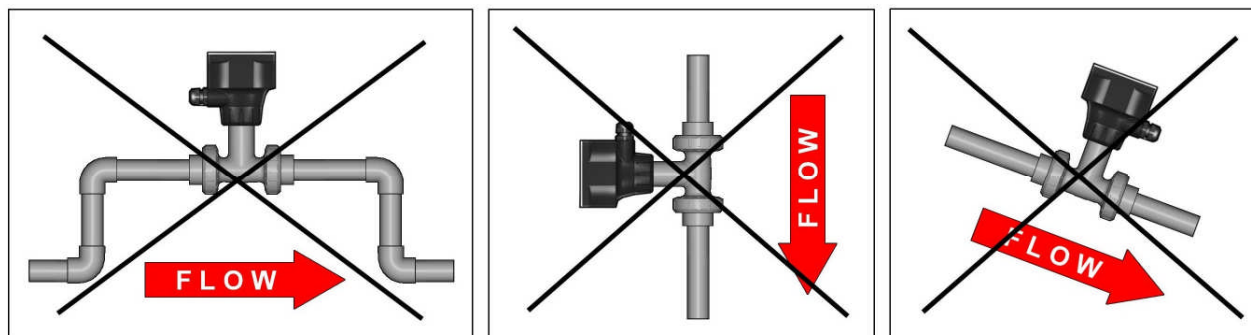

In gravity-flow systems the connection to the tank must be designed so the level does not drop below the outlet: this to avoid pipe to draw air in from the tank causing an erratic measurement of the Magmeter.

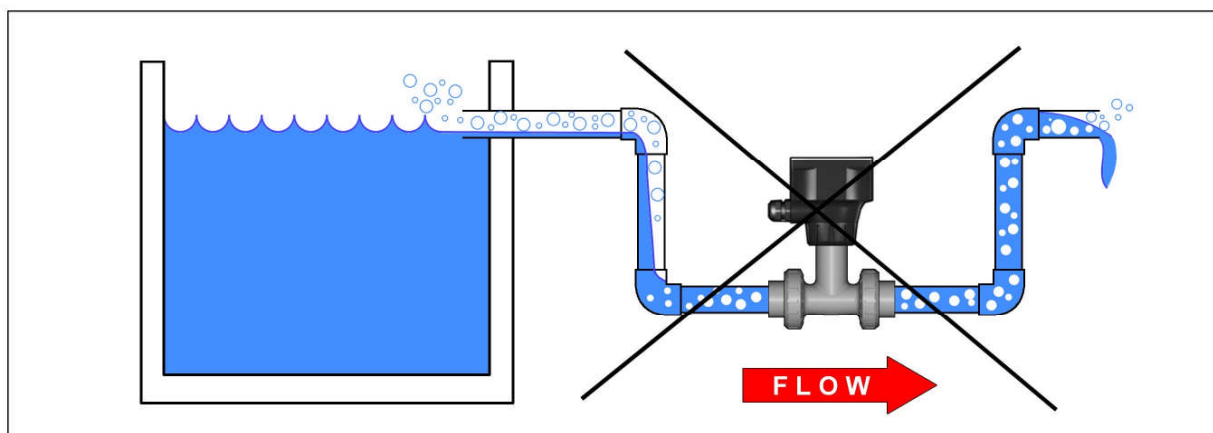

#### 4.4. Wiring

All wiring connections to F9.60 are made via removable terminals. Flow sensor terminals are orange, all other terminals are green.



#### General recommendation

- ❑ Always ensure the power supply is switched off before working on the device.
- ❑ Terminals accept 26 to 12 AWG (0.08 to 2.5 mm<sup>2</sup>)
- ❑ Strip around 10 mm (0.4") of insulation from the wire tips and tin bare ends to avoid fraying.
- ❑ Ferrules are suggested when connecting more than one wire to a single terminal.
- ❑ Remove the upper part of the terminals for an easy cabling.
- ❑ Insert wire tip or ferrule completely into the terminal and fix with the screw until finger tight.
- ❑ The Magmeter output signal may be unstable immediately after the installation. Install the sensor in a full pipe for 24 hours will stabilize the performance. With a very low Electrical Conductivity could be necessary a longer conditioning period.
- ❑ Use electrical cables with the proper external diameter for the liquid tight connector:
  - PG11: external diameter between 2-7 mm (0.079-0.276")
  - PG13,5: external diameter between 5-12 mm (0.197-0.472")



## Rear Terminal View

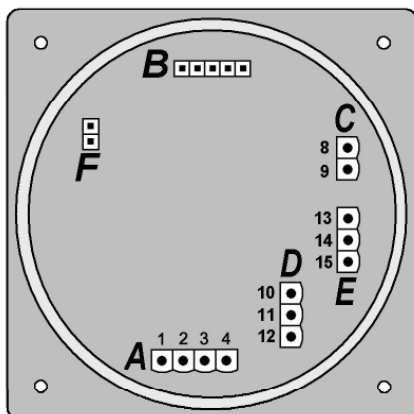

Power supply	A	1	+ VDC
		2	+ LOOP
		3	- LOOP
		4	- VDC
Sensor connection		B	
Open Collector Output	C	8	O.C.+
		9	O.C.-
Out 1 RELAY	D	RELAY 1	
		10	NC
		11	COM
Out 2 RELAY	E	RELAY 2	
		13	NC
		14	COM
Sensor connection		F	

## Power / Loop Wiring Diagram

Stand-alone application,  
no current loop used

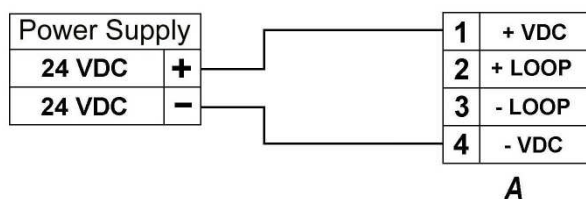

Connection to a PLC with built-in  
power supply (3 wire connection)

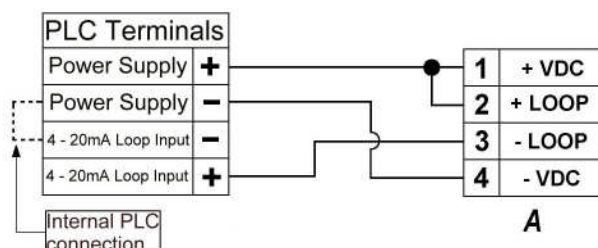

Connection to a PLC / Instrument with ONE separate power supply

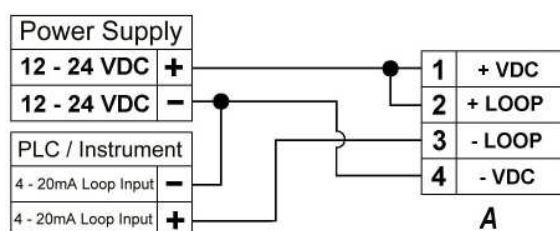

or

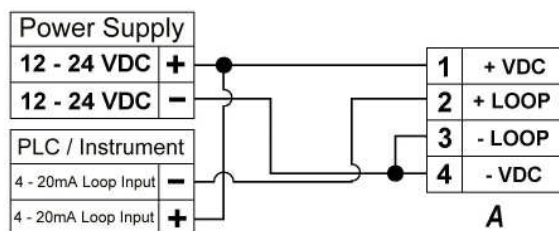

## Connection to a PLC / Instrument with TWO separate power supplies

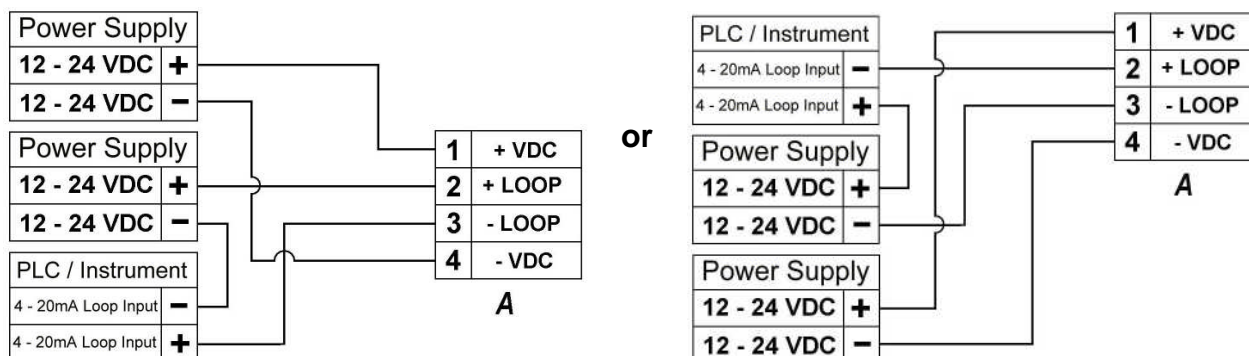

## Open Collector Wiring Diagram

Connection to a PLC  
Open Collector input

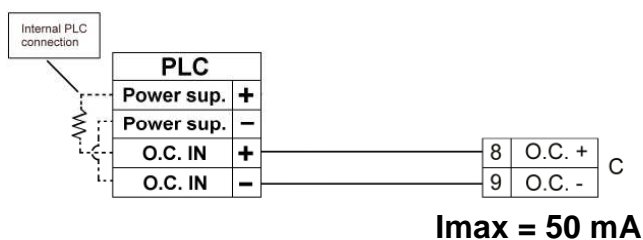

Connection to a PLC / Instrument  
digital input with separate Power Supply

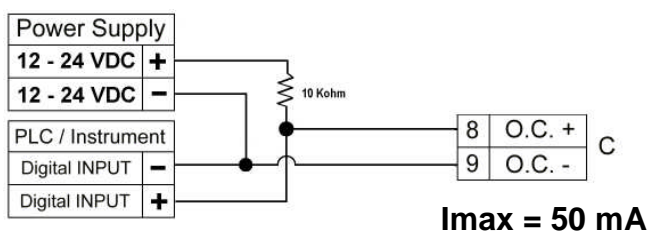

## Connection to FlowX3 Instruments

Flow X3 monitor  
terminals

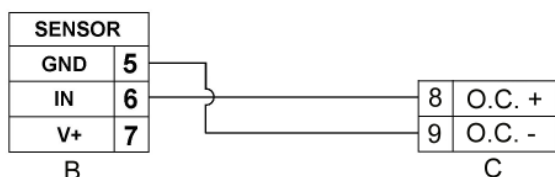

## Relay Wiring Diagram

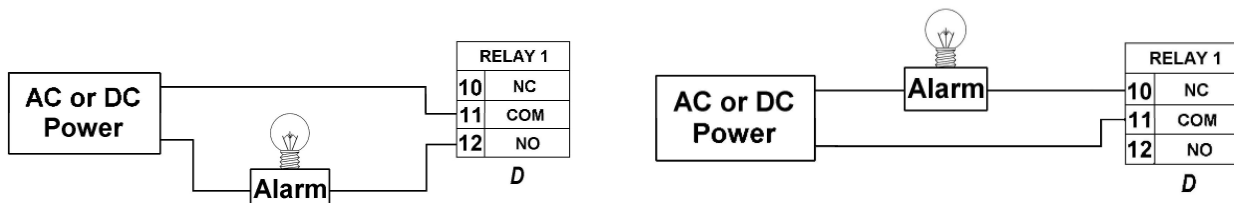

The alarm is OFF during normal operation and goes ON according to Relay settings.

The alarm is ON during normal operation and goes OFF according to Relay settings

## 5. Operational Overview

The FLOWX3 NEW F9.60M Insertion Magmeter like all members of X3 Line, features a digital display and a five-button keypad for system set-up, calibration and operation. This section contains a description of the keypad functions and the general operation flowchart of the instrument.

### 5.1. Keypad Functions

The five push buttons of the keypad are used to navigate display levels and modify settings.



The function of each button may change according to display level; please refer to following table:

Level	Function				
View	Scroll through items	Scroll through items	Select items marked with >	-----	Go to Menu Directory Level
Menu Directory	Scroll through items	Scroll through items	Enter menu for editing	Return to View	-----
Menu	Scroll through items	Scroll through items	Enter menu item for editing	Return to Menu Directory	-----
Edit	Modify an item or a flashing digit	Modify an item or a flashing digit	Scroll right through flashing digits	Return to Menu without saving	Save new settings

### 5.2. General Operation Flowchart

The F9.60 flow monitor and transmitter features four different levels as shown in the following flowchart illustrating the basic navigation concepts.

- ❑ **View Level:** this is the default level. After instrument set-up, all measured values and status of outputs will be available. Refer to section 6. **View Level** for details.
- ❑ **Menu Directory Level:** there are two different Menu Directories for different set-up and calibration. Refer to section 7. **Menu Directory Level** for details. Access to this level can be free or password protected. Entering the correct password allows direct access to next levels and to all editable items in all menus, until a return to View Level.
- ❑ **Menu Level:** the current setting for each item in a Menu can be viewed and selected for editing at this level.
- ❑ **Edit Level:** all instrument parameters can be set, modified and saved at this level. Refer to section 8. **Menu and Edit Levels** for details.

# Operation Flowchart

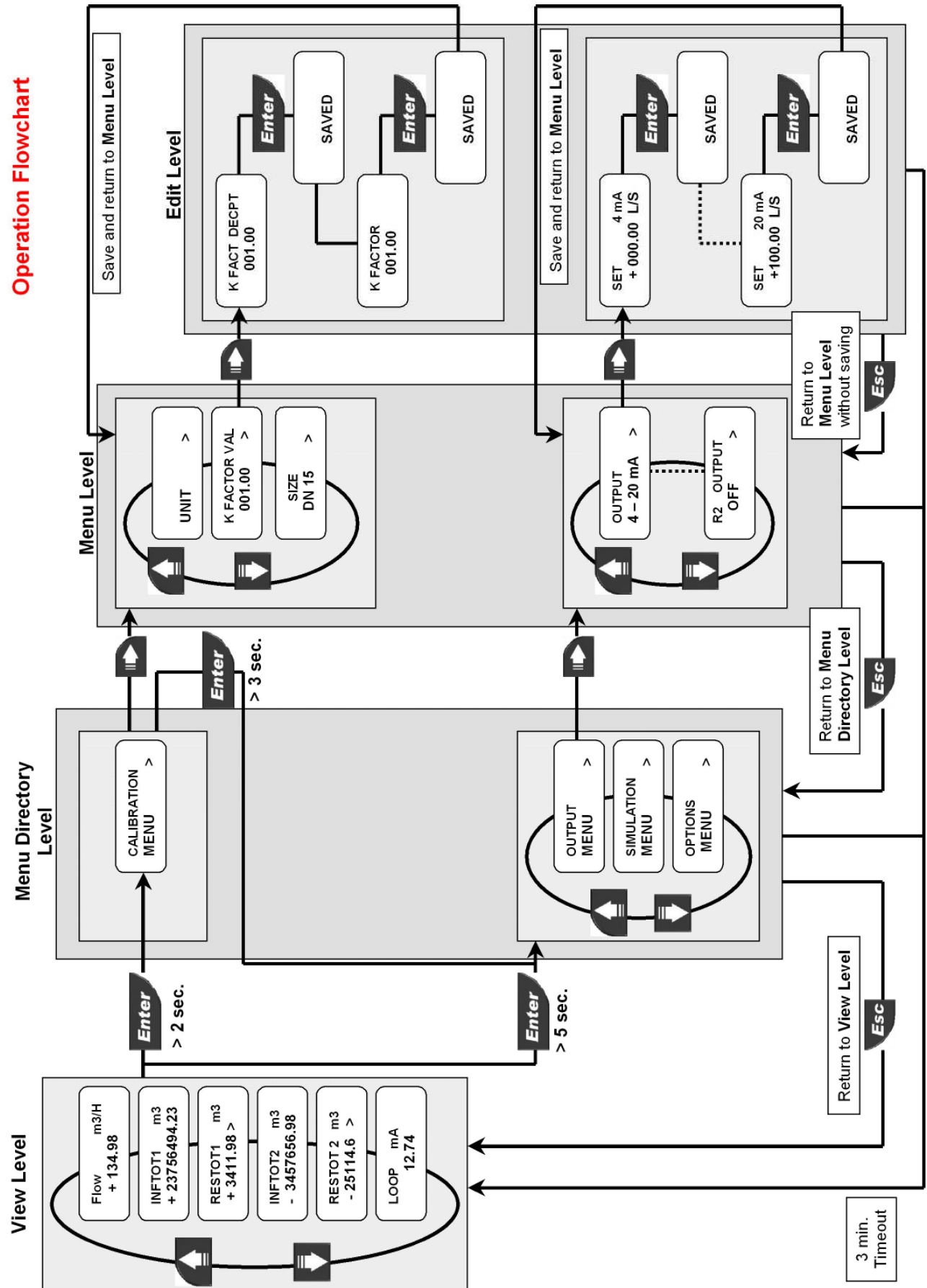

## 6. View Level

- During normal operation, the flow monitor and transmitter is in View Level displaying all measured values and the status of the analog output, O.C. and Relay output.
- If the flow monitor is in a different level and no activity occurs for more than 3 minutes, it will return to View Level.
- To select the item you want displayed, press UP or DOWN arrows.
- **Changing display indication does not affect or interrupt instrument operation and calculation.**

	Description
	Flow rate positive or negative
	Positive Permanent totalizer value
	Positive Resettable totalizer value. Press the RIGHT arrow key to reset. If locked, you will need to enter the password first. Lock or unlock the total reset in Option Menu (refer to <b>section 8.4.9. Restot PWD</b> for details)
	Negative Permanent totalizer value
	Negative Resettable totalizer value. Press the RIGHT arrow key to reset. If locked, you will need to enter the password first. Lock or unlock the total reset in Option Menu (refer to <b>section 8.4.9. Restot PWD</b> for details)
	4 – 20mA Loop Output

## 7. Menu Directory Level

Access to this level can be free or password protected. Entering the correct password allows direct access to next levels and to all editable items in all menus, until a return to View Level (refer to **section 8.4.8. Menu PWD** to select password protected access).

Four different menus are available to fully set-up the F9.60 magmeter. These menus are separated in two different Menu Directories.

In terms of getting started and making measurements, Calibration Menu is the most important menu in the F9.60 and it is the only one included in the first Menu Directory.

Output Menu, Simulation Menu and Option Menu are included together in the second Menu Directory.

### 7.1. Free access (no password required)

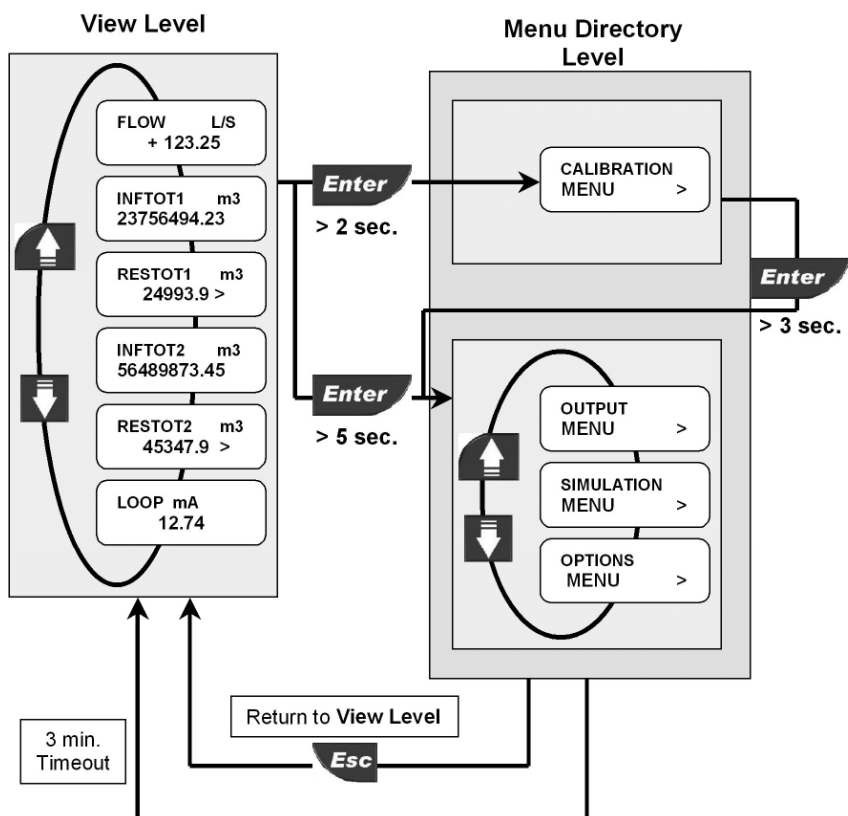

### 7.2. Password protected access

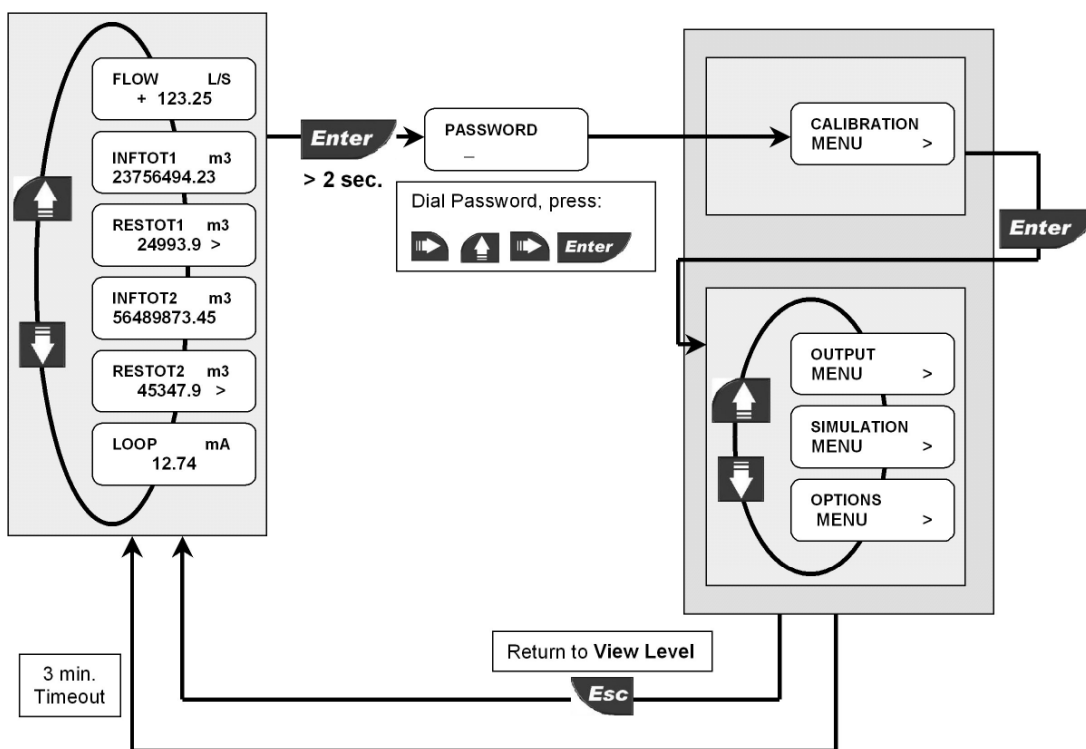

## 8. Menu and Edit Levels

### 8.1. Calibration Menu

The F9.63 basic settings are made in this menu:

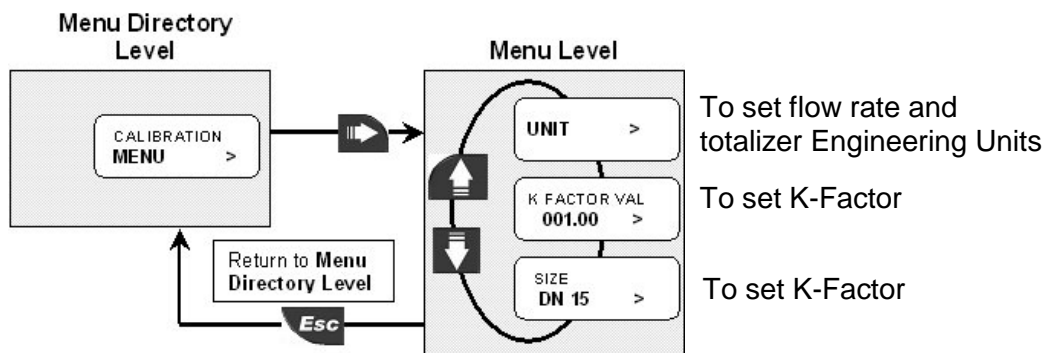

#### 8.1.1. Unit

Set the engineering units for the instant flow rate and the total flow rate. All the options available are displayed on the LCD.

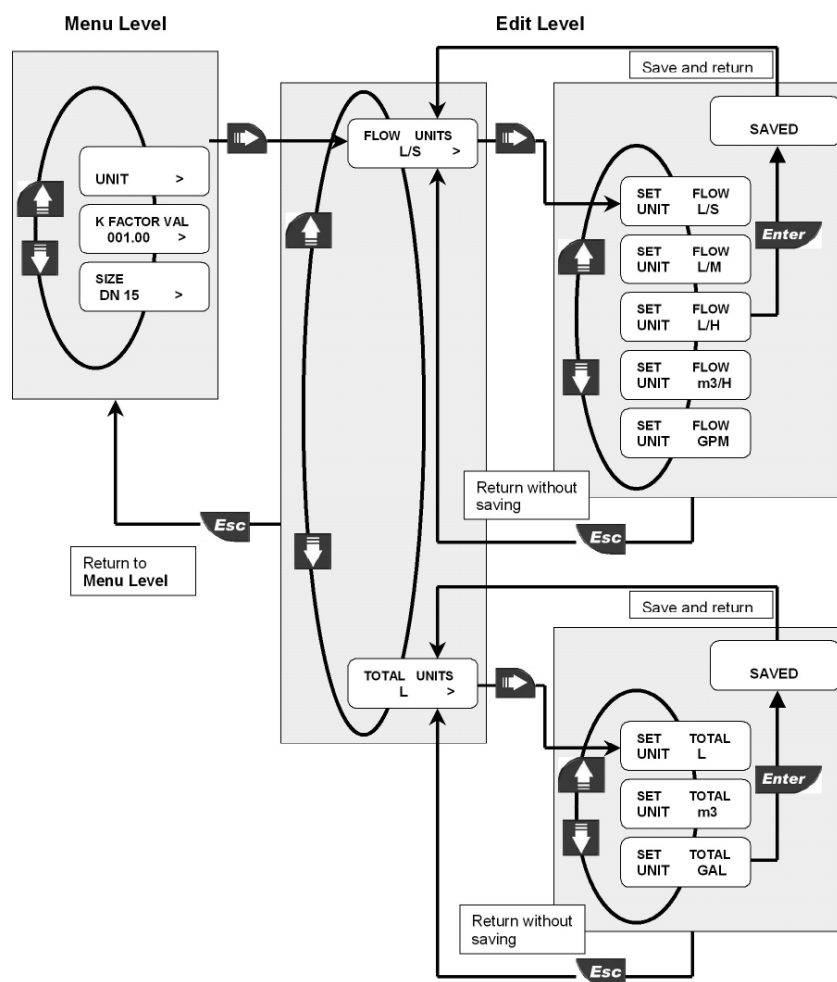

The instrument will automatically convert the values of the two totalizers in the new engineering units.

### 8.1.2. K-Factor

Set the K-Factor to tell the monitor and transmitter how to convert the input frequency from the flow sensor into a flow rate. The K-factor is unique to the sensor model and to the pipe size and material.

Refer to section **10. K-Factor Tables** for the correct value.

Limits: 000.01 to 99999 (the K-Factor cannot be set to 0)

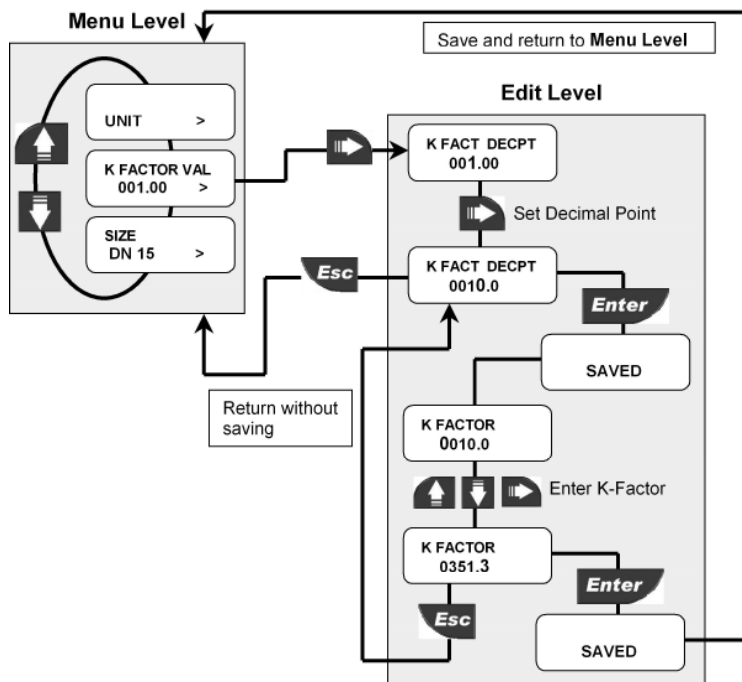

### 8.1.3. Size

To select pipe's size allows ASEC to improve instrument's performance.

You can choose between standard sizes from DN15 to DN300. For pipes bigger than DN300 choose DN300.

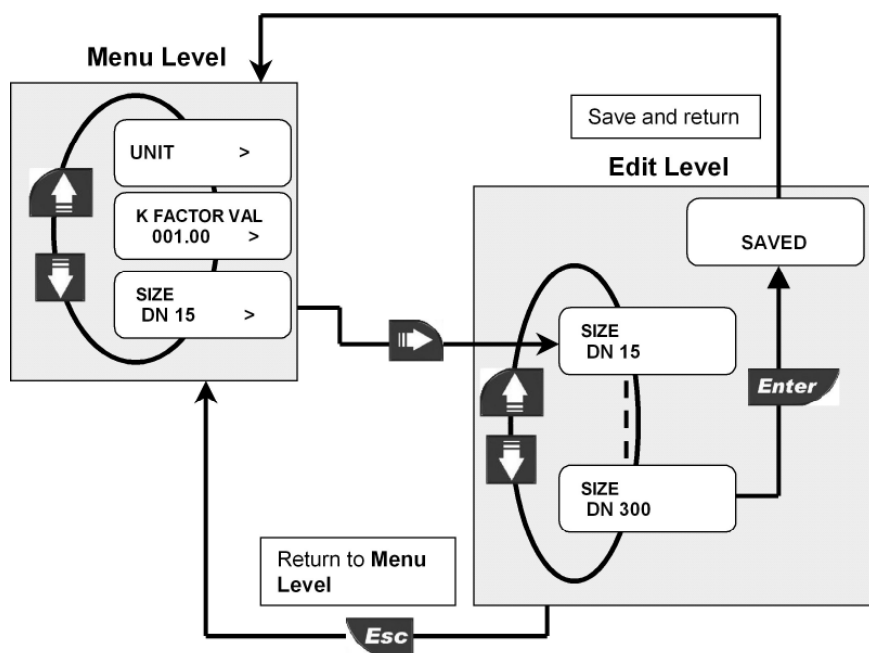



## 8.2. Output Menu

The F9.60 analog and digital output are set-up in this menu:

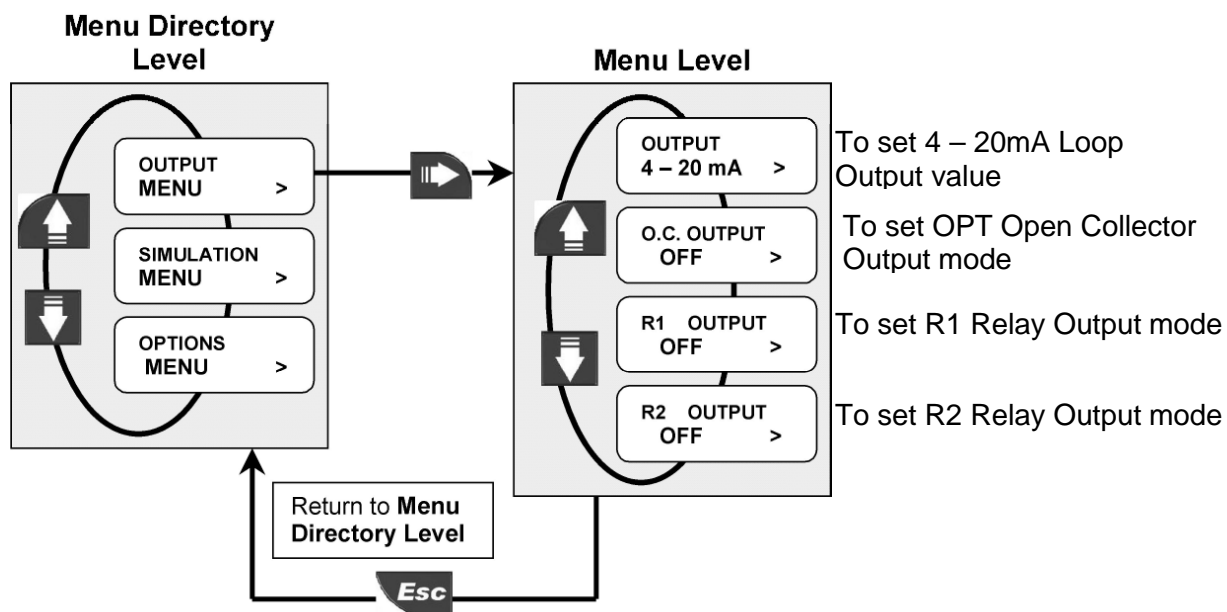

## 4 - 20mA Output

The measuring range of the flow, corresponding to the 4-20mA output current is entered here by setting before the sign and after the value for the 4mA and before the sign and after the value for the 20mA. The F9.60 will allow any value from 0.0000 to 99999 and the beginning of the measuring range can be larger than the end of it.

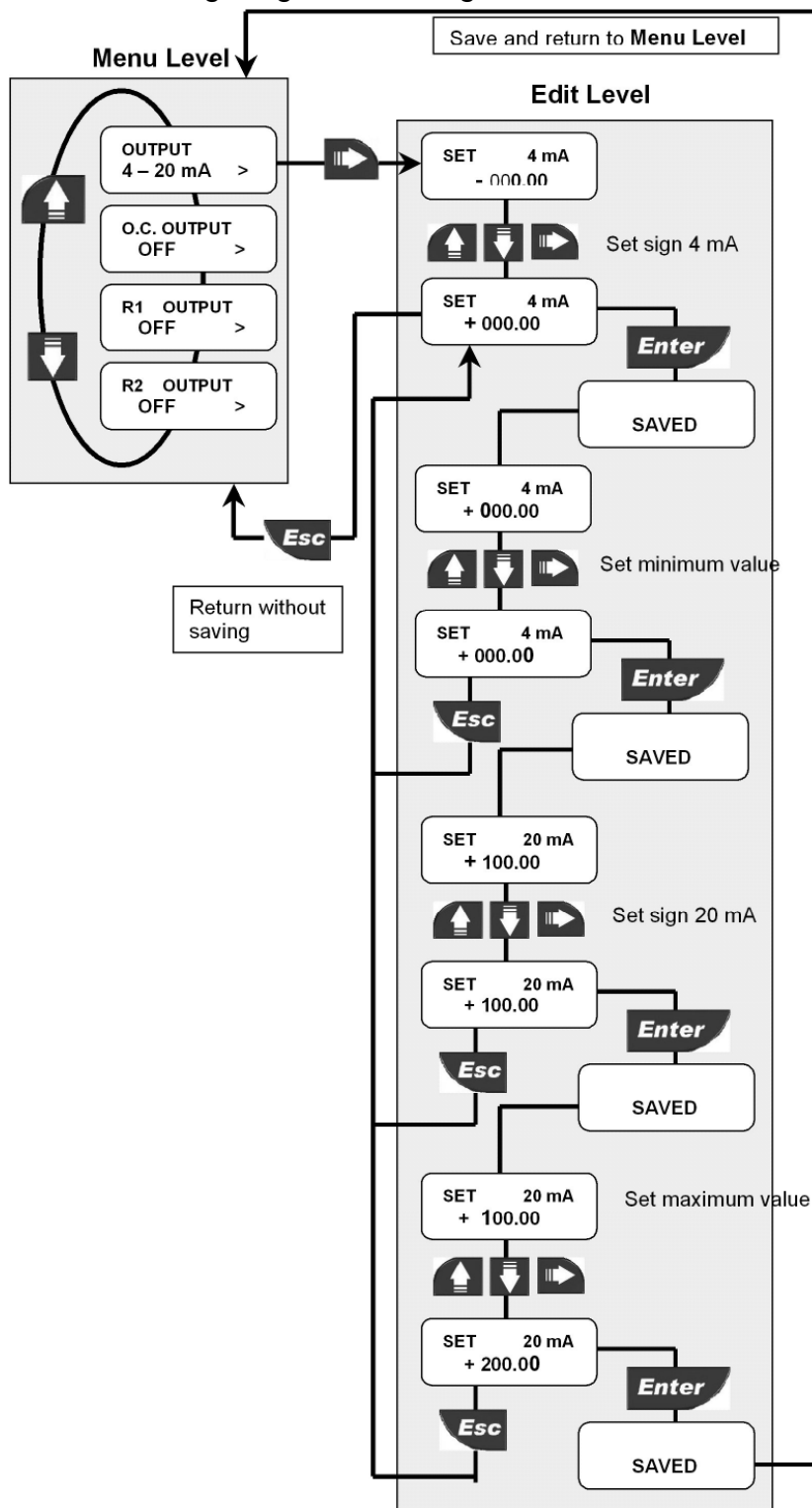

## O.C. Output (OPT)

All OC Output (OPT) settings repeat for R1 and R2 Output (OUT1-OUT2)

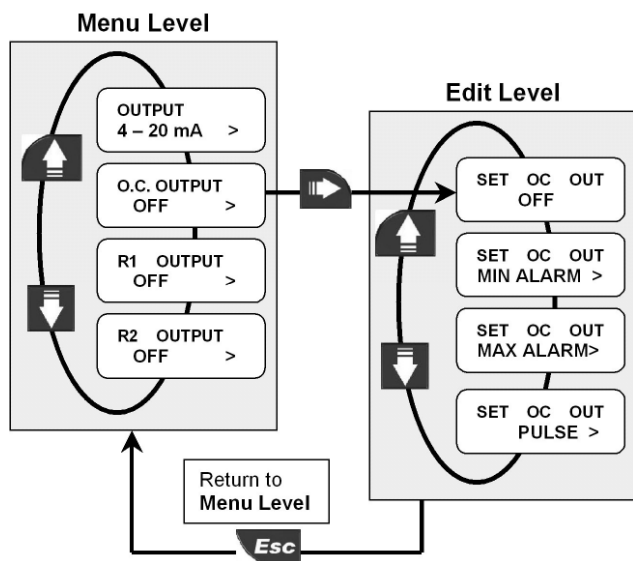

The mode of operation for the Open Collector Output (OPT) can be selected between different options: MIN alarm, MAX alarm, Window or volumetric Pulse.

The signal can be disabled (set to OFF) if not used.

If the O.C. Output is programmed the OPT icon will appear on the third line of the display.

### 8.2.2.1. O.C. Output (OPT): MIN mode

The output triggers when the flow rate drops below the setpoint: LED placed below OPT icon will switch on. The output will relax when the flow rate moves above the setpoint plus the hysteresis value.

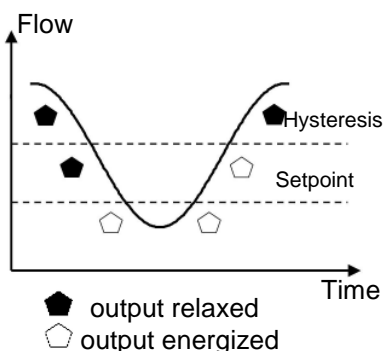
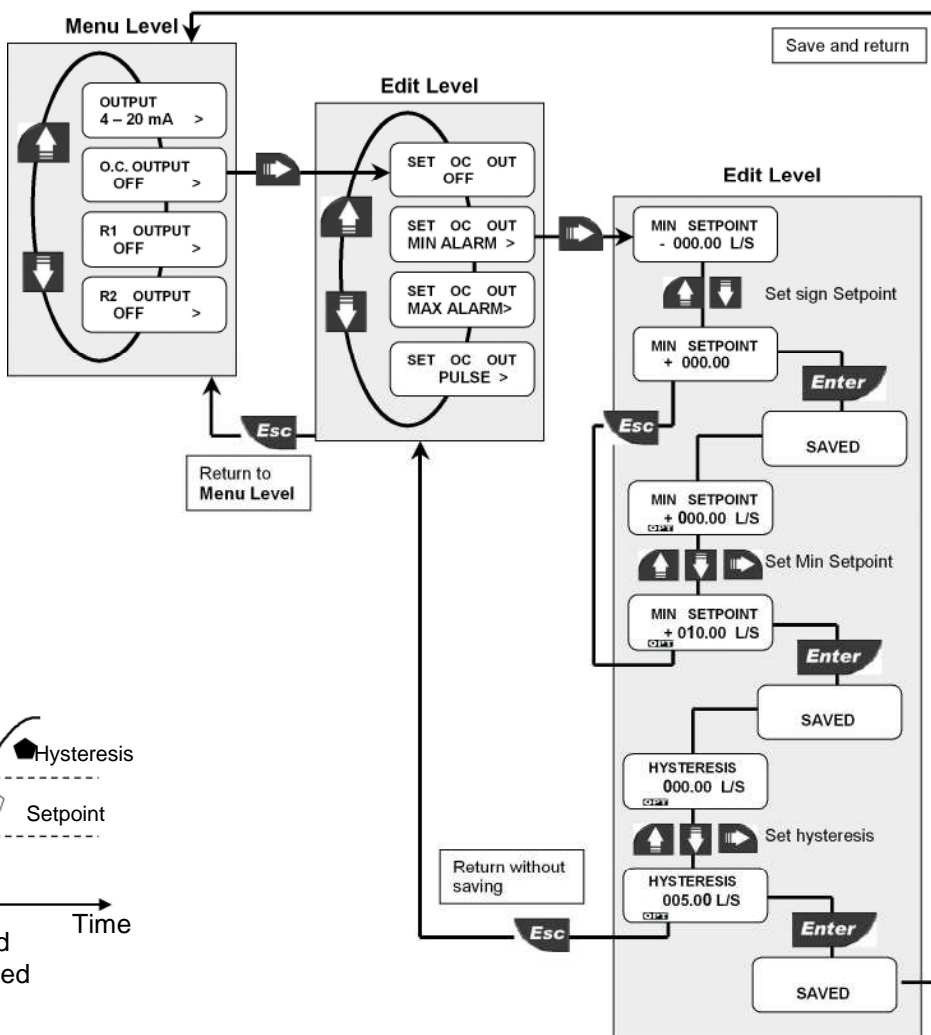

### 8.2.2.2. O.C. Output (OPT): MAX mode

The output triggers when the flow rate is greater than the setpoint: LED placed below OPT icon will switch on. The output will relax when the flow rate drops below the setpoint plus the hysteresis value.

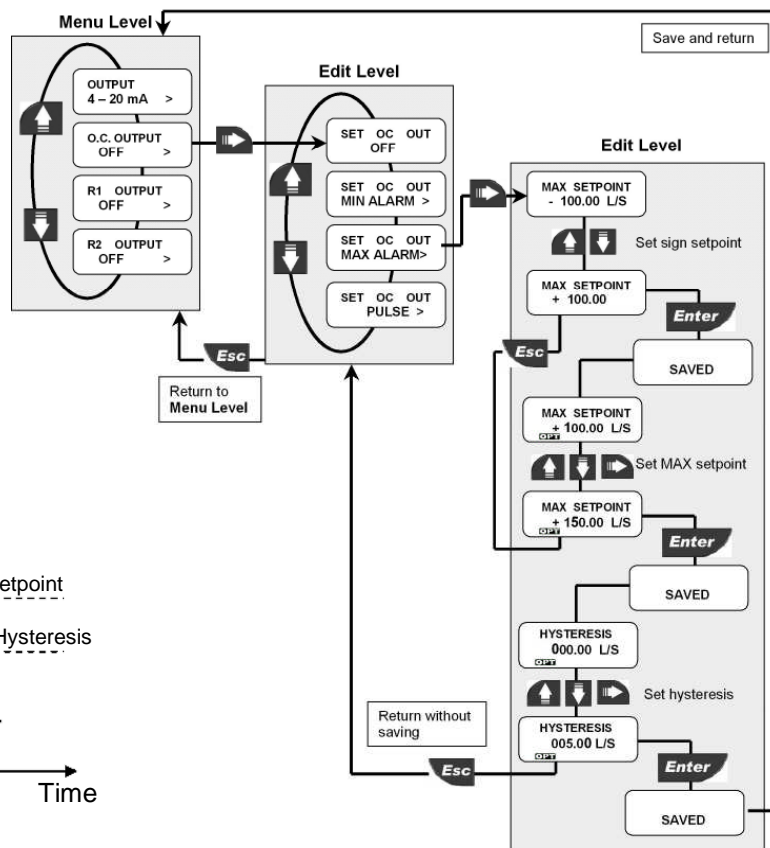
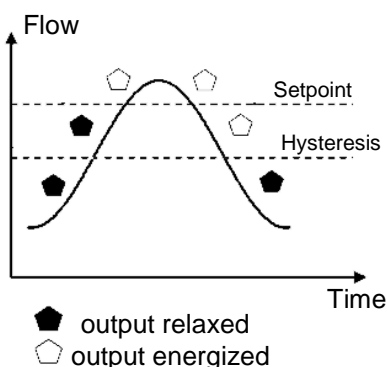

### 8.2.2.3. O.C. Output (OPT): PULSE mode

In PULSE mode the O.C. output will generate a pulse when the set volume passes the sensor. ENTER any value from 0.0001 to 99999. The duration of the pulse can be chosen from 000.1 to 999.9 seconds.

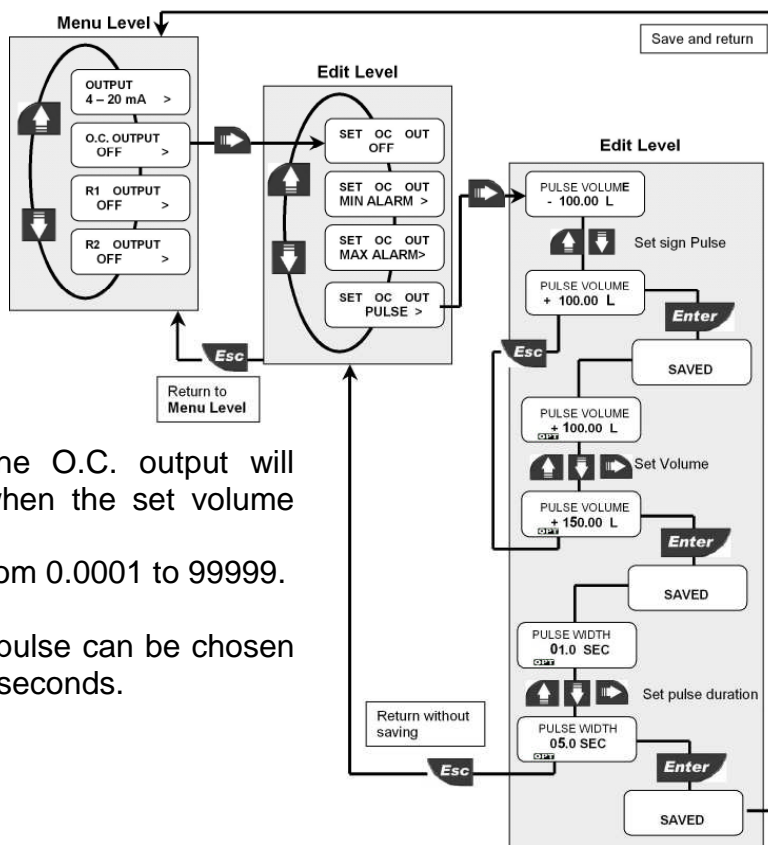

### 8.3. Simulation Menu

The F9.60 analog and digital output can be simulated and tested in this menu:

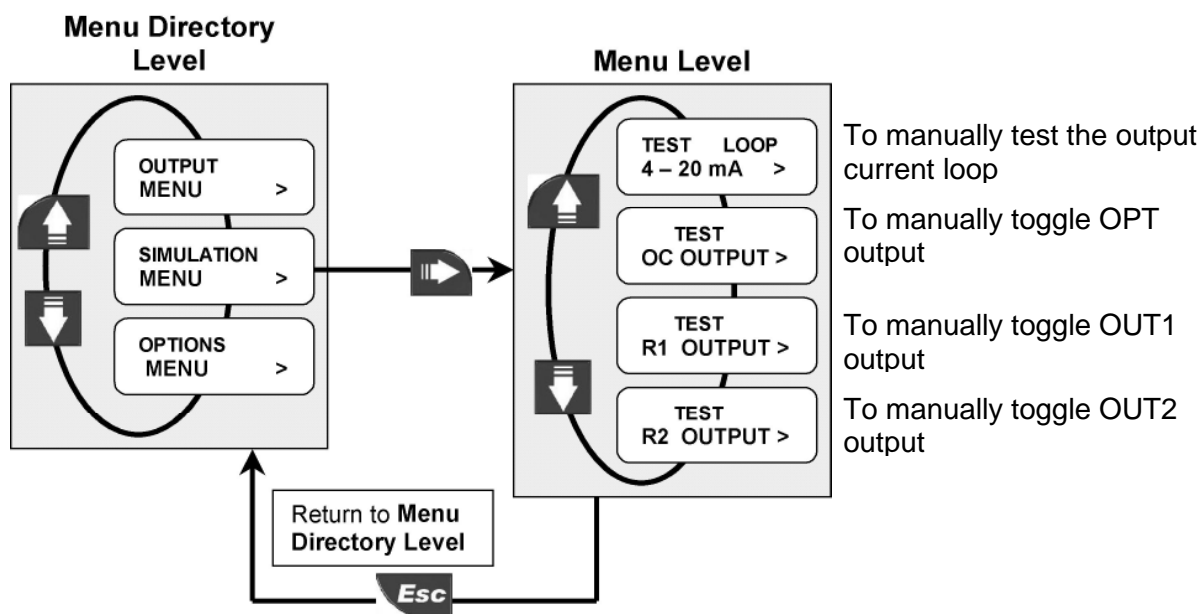

#### 8.3.1. Test 4 – 20mA Loop

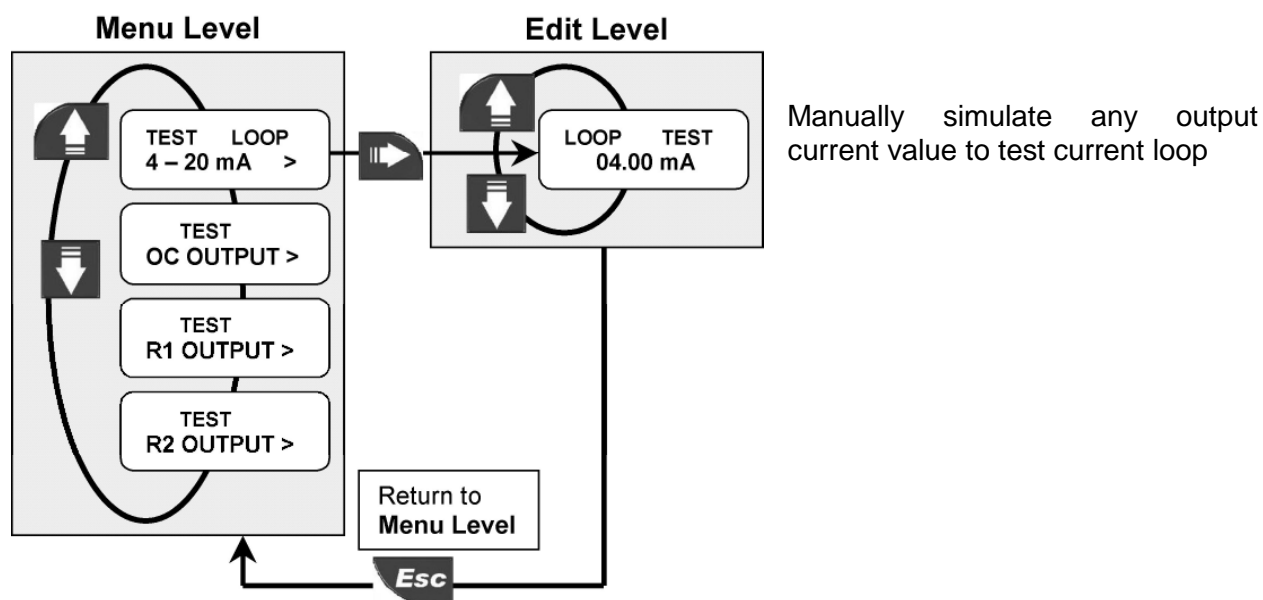

### 8.3.2. Test O.C. Output (OPT)

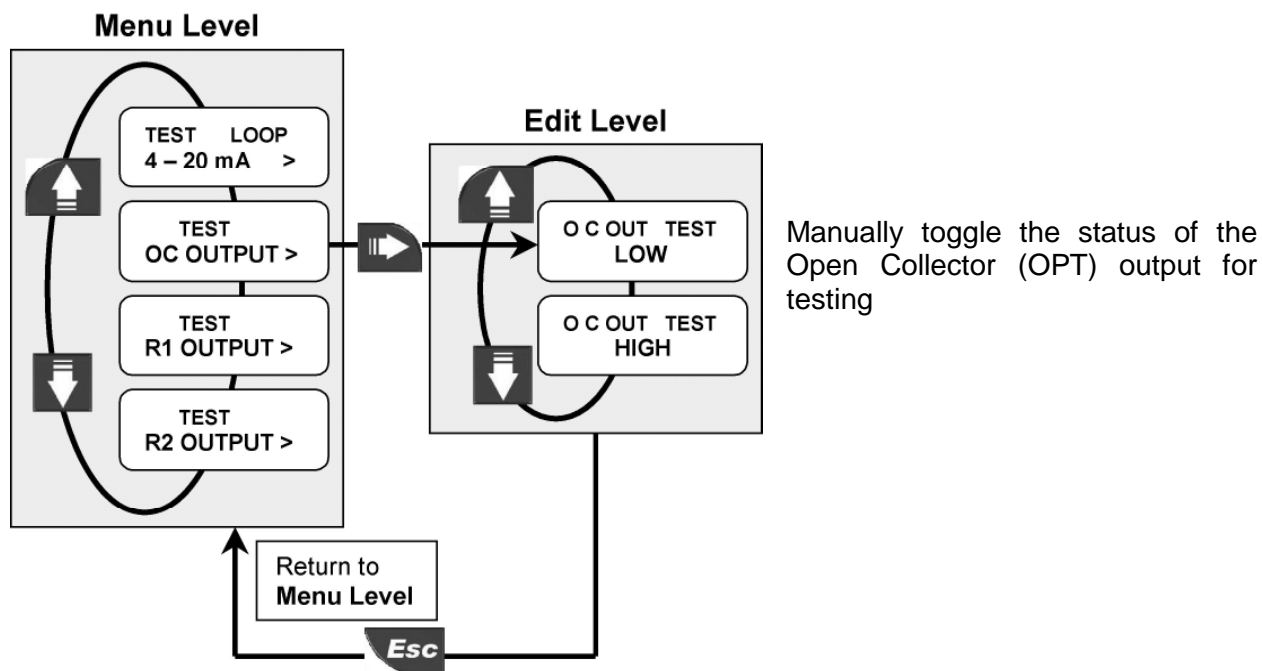

### 8.3.3. Test R1 Output (OUT1)

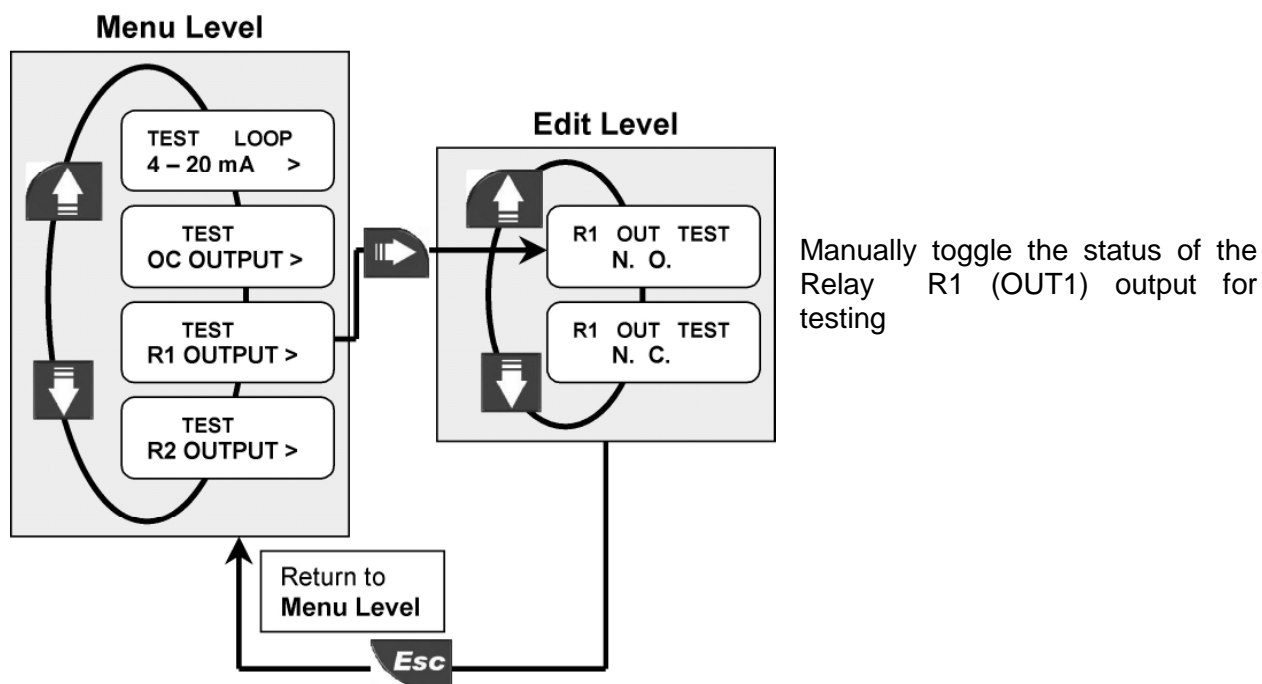

R1 Output (OUT1) test repeats for R2 Output (OUT2)

## 8.4. Options Menu

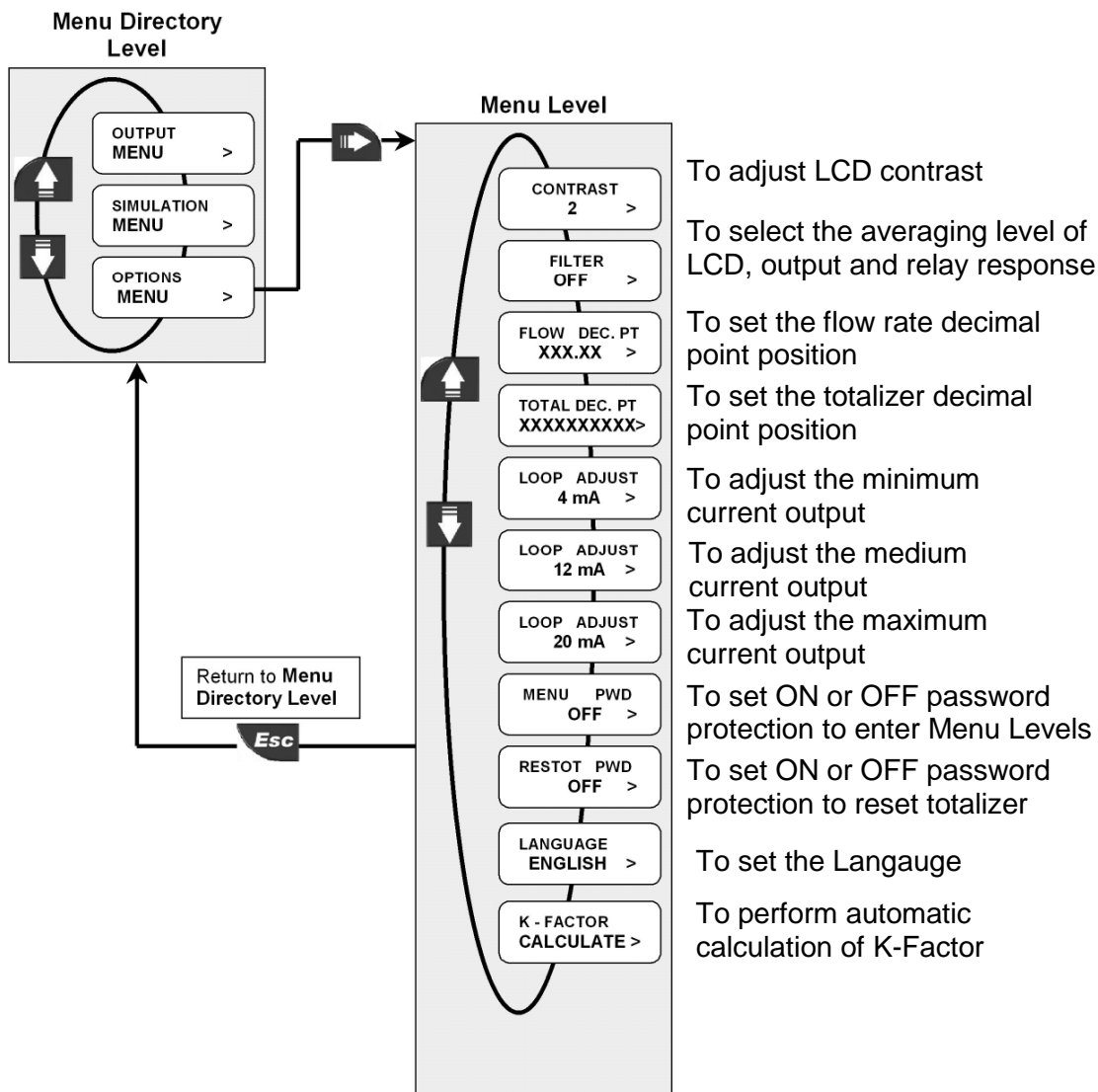

### 8.4.1. Contrast

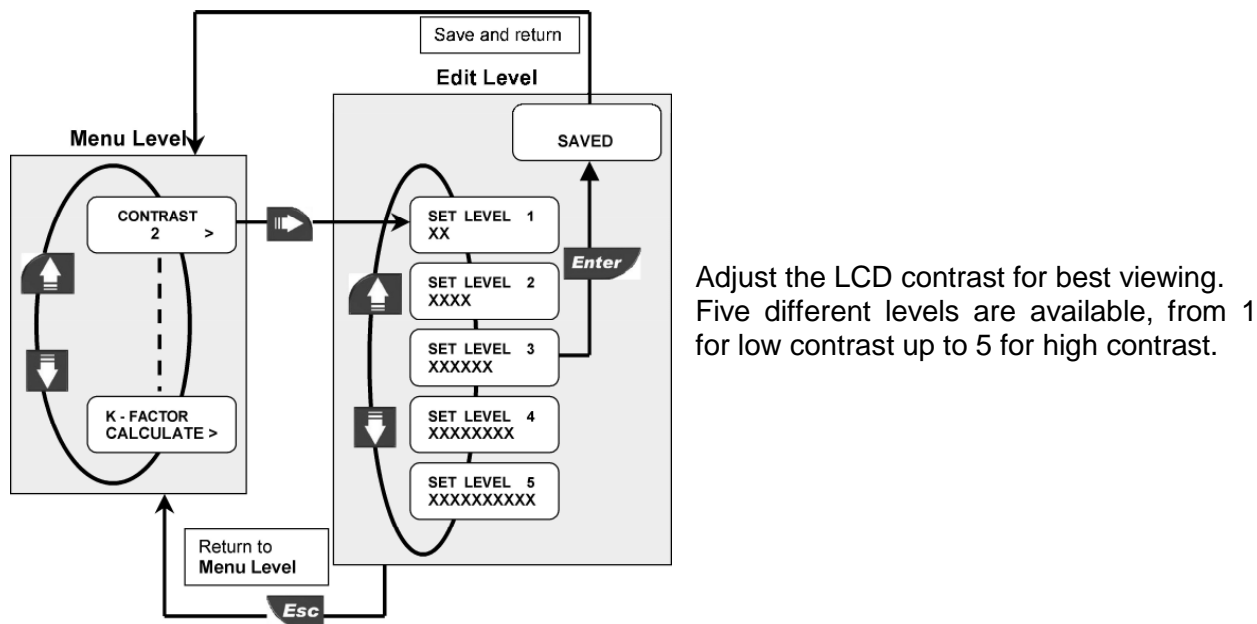

### 8.4.2. Filter

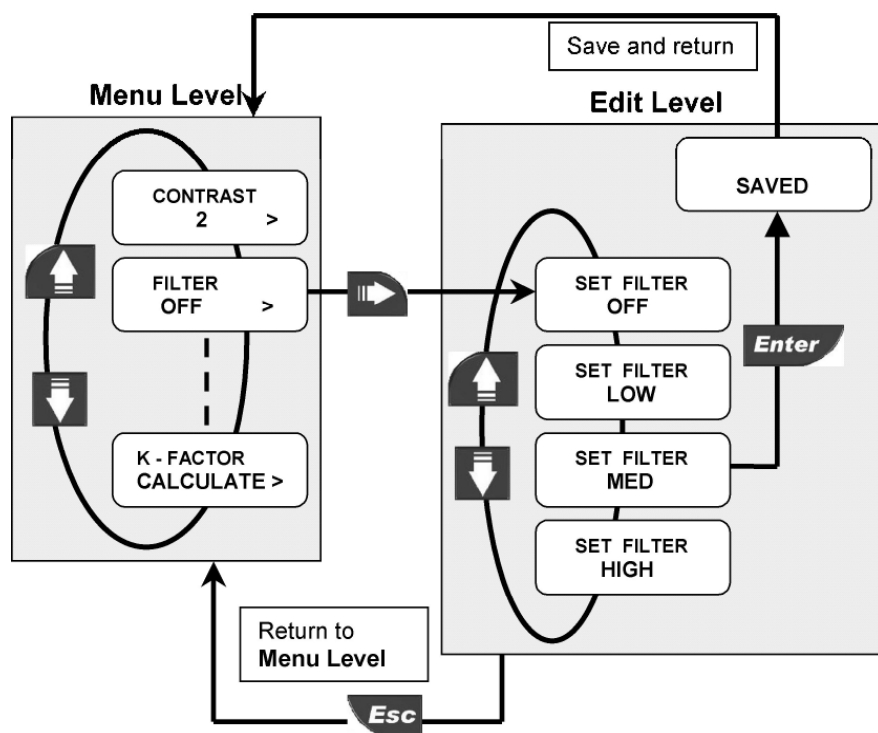

Select the averaging level to dampen LCD indication, output and relay response. **OFF**: no dampening effect, near instantaneous response.

### 8.4.3. Flow Decimal Point

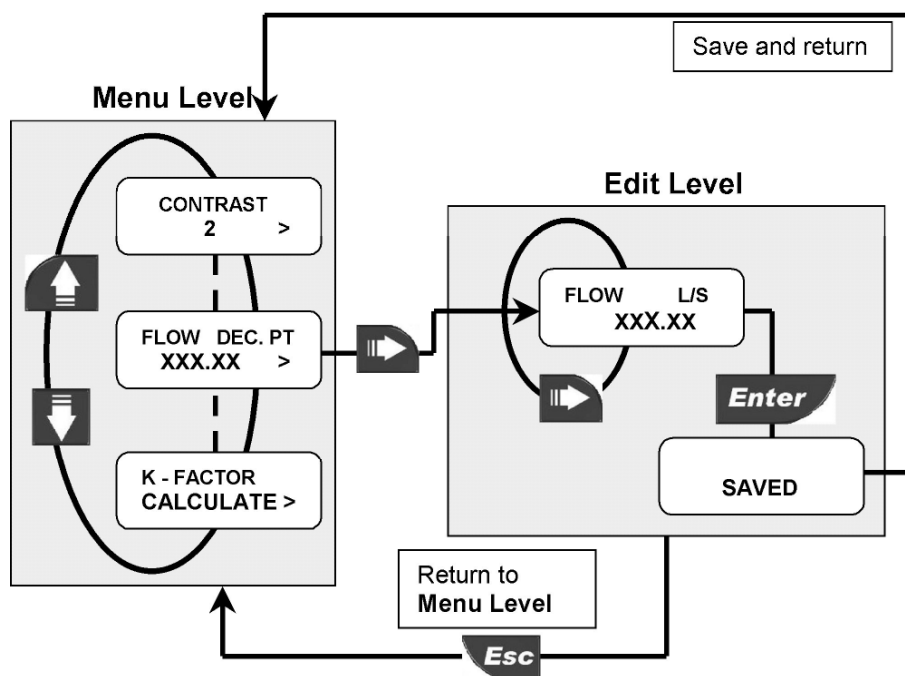

Set the decimal point position to get the best resolution for the application. Select one of the following options:  
**X.XXXX ; XX.XXX ;**  
**XXX.XX ; XXXX.X ;**  
**XXXXX.**



### 8.4.4. Total Decimal Point

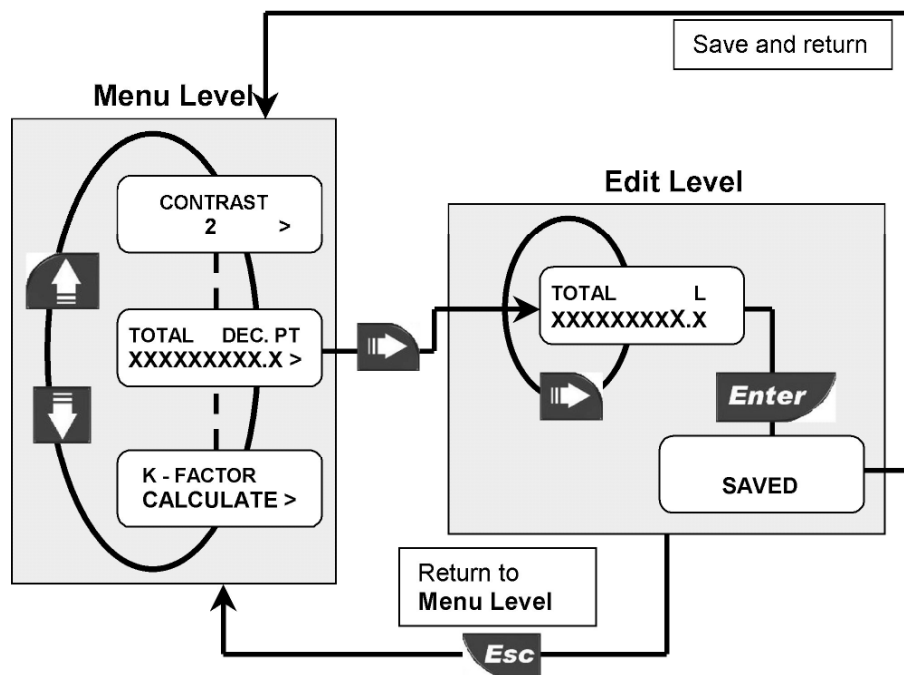

Set the decimal point position to get the best resolution for the application. Select one of the following options  
 XXXXXXXX.XX  
 XXXXXXXXX.X  
 XXXXXXXXXX.

### 8.4.5. Loop Adjust 4mA

This option can be used to modify the basic 4mA setting to match the transmitter output to any external device.

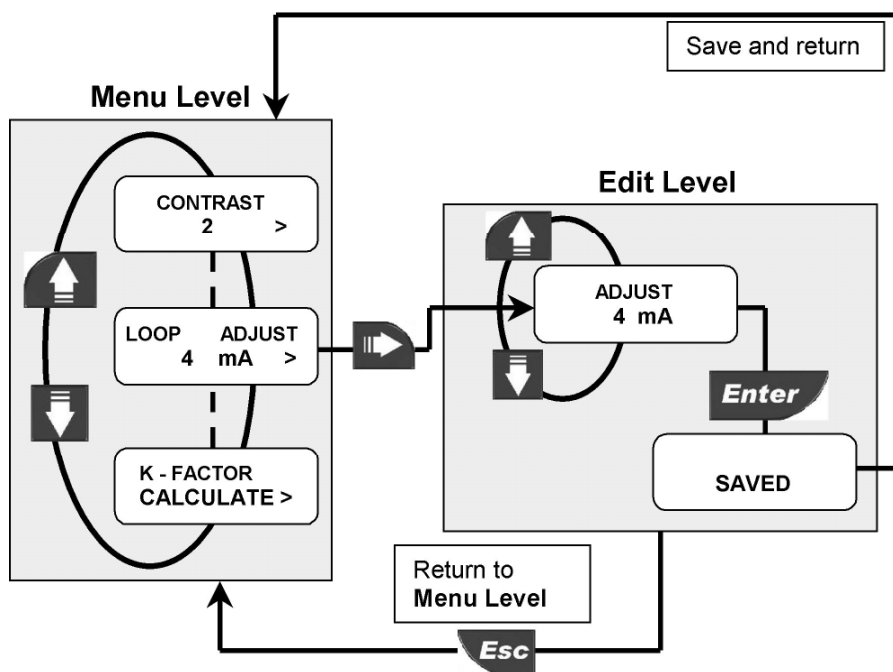

Increment output current value by pressing UP arrow key or decrement it by pressing DOWN arrow key.

### 8.4.6. Loop Adjust 12mA

This option can be used to modify the basic 12mA setting to match the transmitter output to any external device.

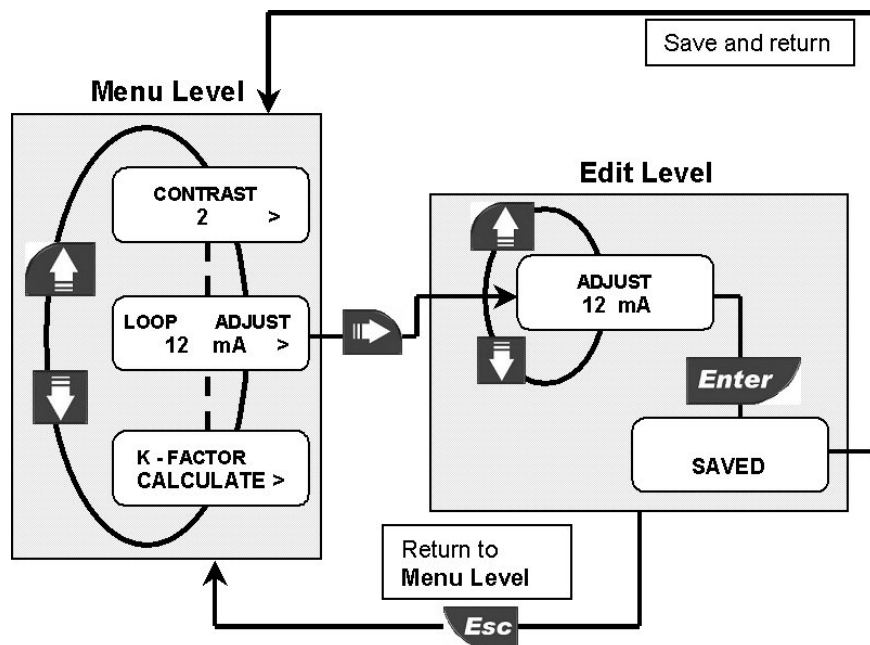

Increment output current value by pressing UP arrow key or decrement it by pressing DOWN arrow key.

### 8.4.7. Loop Adjust 20mA

This option can be used to modify the basic 20mA setting to match the transmitter output to any external device.

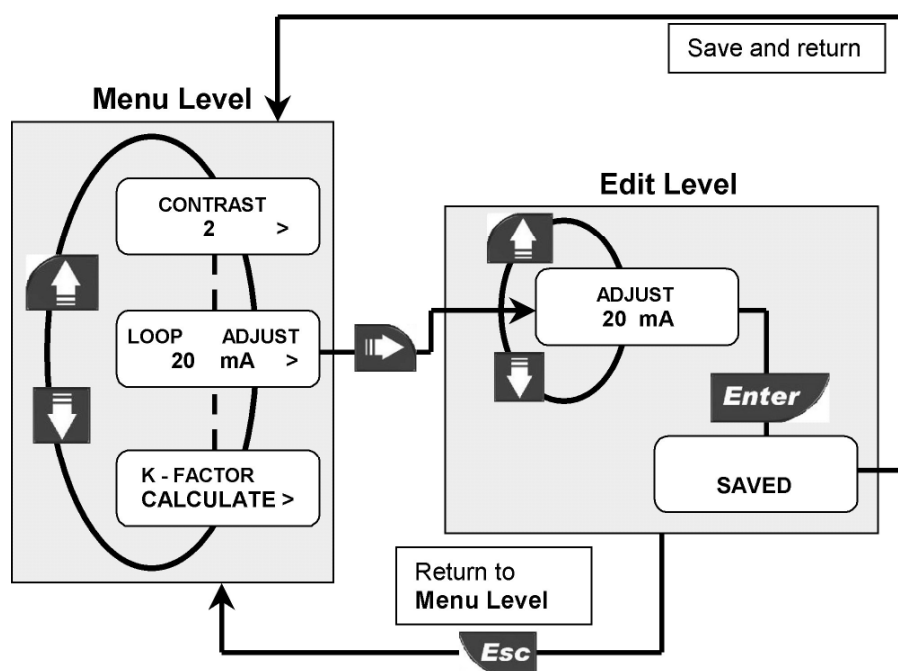

Increment output current value by pressing UP arrow key or decrement it by pressing DOWN arrow key.

### 8.4.8. Menu PWD

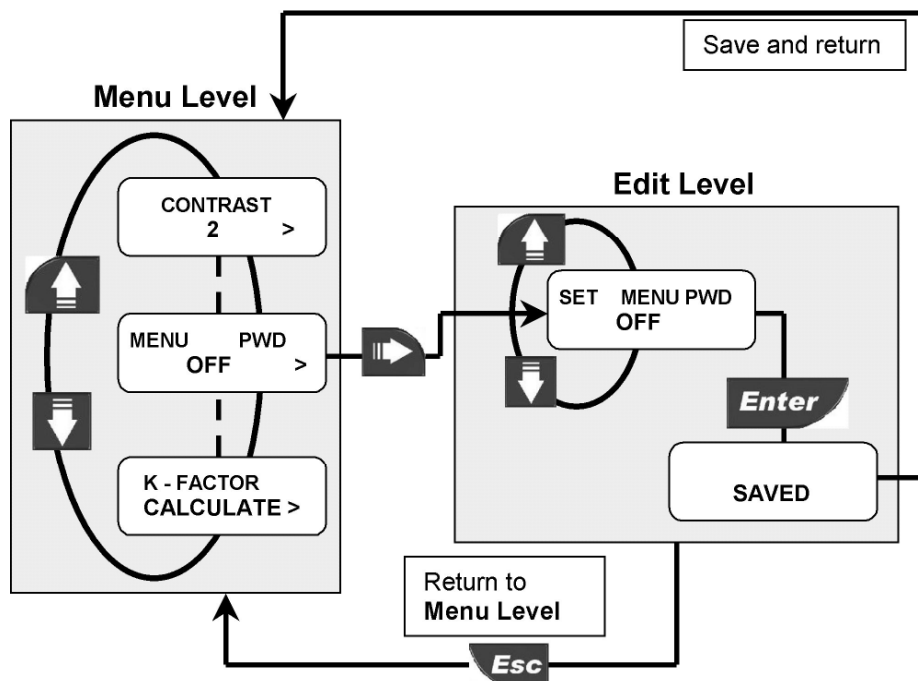

Set ON the Menu PWD to protect access to Menu Directory Level and next levels.

**NOTE:** the standard password is **Enter** and it cannot be modified.

### 8.4.9. Restot PWD

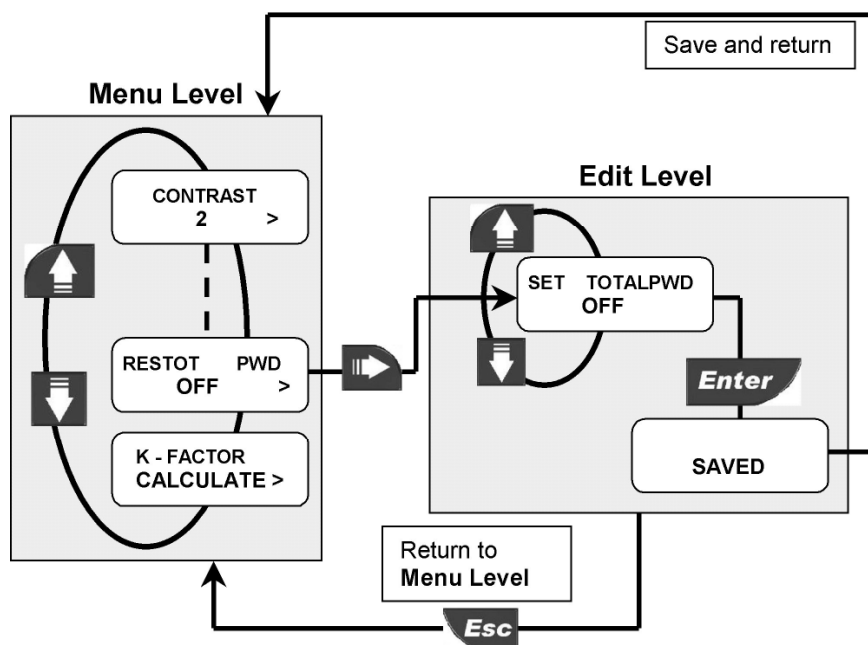

Set ON the Restot PWD to protect the resettable totalizer from undesired reset operations.

**NOTE:** the standard password is **Enter** and it cannot be modified.

### 8.4.10. Language

This option offers to select the display language

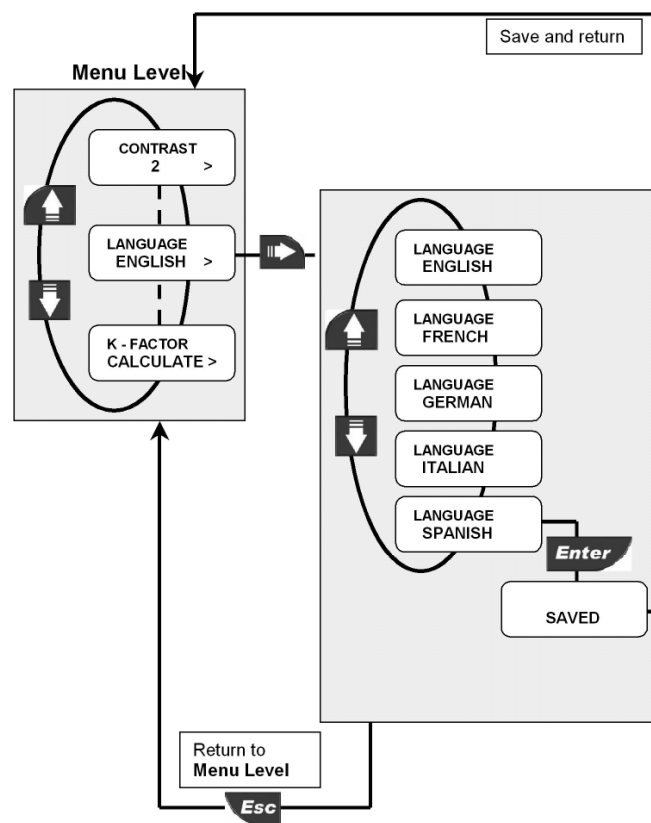

### 8.4.11. K-Factor Calculate

Option used to perform automatic calculation of K-Factor by measuring the volume filled into a tank. This to get the highest accuracy possible.

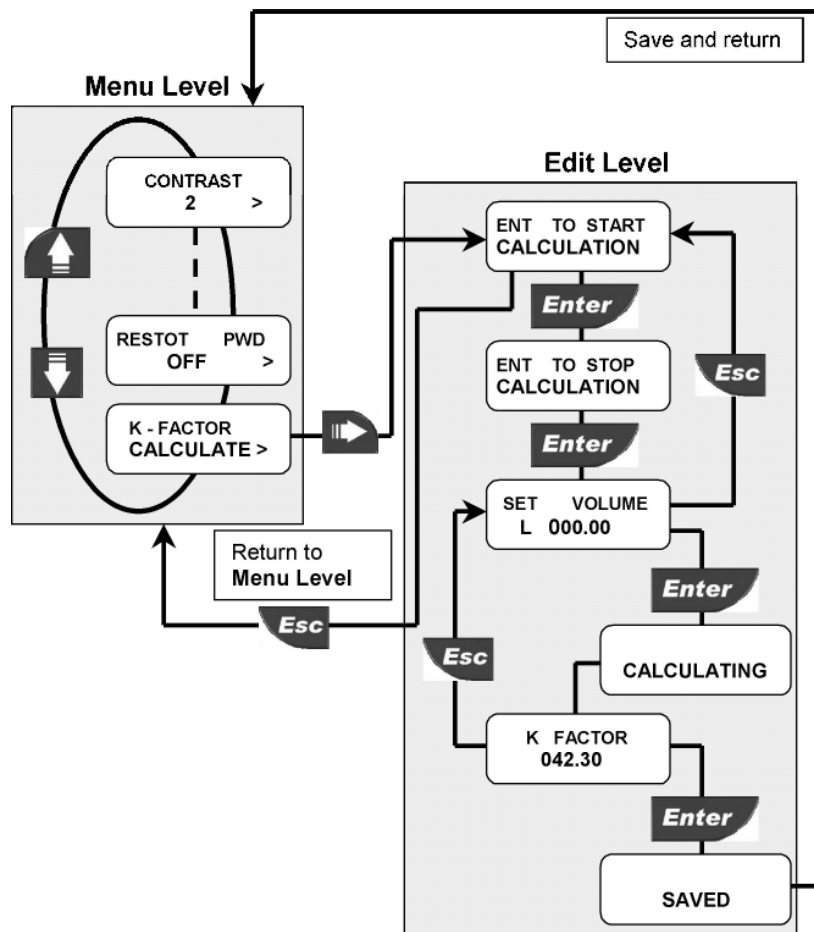

Press ENTER to start calculation. Switch on a pump or open a valve. F9.60 starts counting pulses from the sensor.

When the tank is full, switch off the pump or close the valve. Press ENTER to stop calculation. F9.02 stops counting pulses from the sensor.

Enter the volume (in liter) of fluid filled into the tank.









F9.60 is calculating the new K-Factor.

Successful K-Factor calculation. Press ENTER to accept new K-Factor or ESC to return without saving.

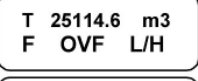
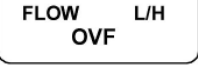
## 9. Troubleshooting

The instrument correctly installed is maintenance-free. The case and the front panel can be cleaned with soft cloth and an appropriate cleaning agent.

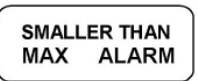
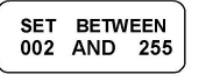
### 9.1. Display messages

Display	Causes	Solutions
	<ul style="list-style-type: none"> <li>The display is OFF: no power supply provided</li> </ul>	<ul style="list-style-type: none"> <li>Check power supply connection. Check “bridges” between terminals.</li> </ul>
  	<ul style="list-style-type: none"> <li>Flow rate is in OVERFLOW: it exceeds the maximum display capability</li> </ul>	<ul style="list-style-type: none"> <li>Change the flow rate engineering units</li> </ul>
	<ul style="list-style-type: none"> <li>Input frequency is too large</li> </ul>	<ul style="list-style-type: none"> <li>Check sensor connection</li> <li>If not FlowX3 sensor, verify sensor data sheet and compatibility</li> </ul>
	<ul style="list-style-type: none"> <li>K-Factor cannot be set to 0</li> <li>Volume corresponding to one pulse (when setting OPT as Pulse Out) cannot be set to 0</li> <li>Pulse width (when setting OPT as Pulse Out) cannot be set to 0</li> <li>Volume filled into the tank (during K-factor calculation procedure) cannot be set to 0</li> </ul>	<ul style="list-style-type: none"> <li>Enter K-Factor value from 000.01 to 99999</li> <li>Enter any volume from 0.0001 to 99999</li> <li>Enter any pulse width from 000.1 to 999.9 seconds</li> <li>Enter any volume from 000.01 to 999.99</li> </ul>
	<ul style="list-style-type: none"> <li>With the new engineering unit chosen, the totalized volume exceeds maximum display capability</li> </ul>	<ul style="list-style-type: none"> <li>Change the totalizer engineering units</li> </ul>
	<ul style="list-style-type: none"> <li>Hysteresis value is larger than the MAX alarm value: the instrument will never get out of the maximum alarm</li> </ul>	<ul style="list-style-type: none"> <li>Change the hysteresis value</li> </ul>
	<ul style="list-style-type: none"> <li>The dividing value (when setting OPT as Freq Out) is out of range</li> </ul>	<ul style="list-style-type: none"> <li>Enter any value between 002 and 255</li> </ul>
	<ul style="list-style-type: none"> <li>The pulse width is too wide compared to pulse frequency</li> </ul>	<ul style="list-style-type: none"> <li>Increase volume setting</li> <li>Decrease pulse width</li> <li>Reduce flow rate</li> </ul>
	<ul style="list-style-type: none"> <li>The value calculated during the K-Factor calculation procedure is out of range</li> </ul>	<ul style="list-style-type: none"> <li>Move decimal point position</li> <li>Check entered volume</li> </ul>

## 10.K-Factor Table ( only for frequency output )

K-Factor is the number of pulses a sensor produces for one liter of fluid measured. Here all K-Factors for water at ambient temperature are listed.

**K-Factor values can depend upon the installation conditions.**

**Please contact your dealer for K-Factor values not included in the table.**

**F.S. is the Flow rate value ( L/ s ) at 5 m/sec.**

### Installation on PVC pipes

**ISO Metric PVC Tee Fittings for ISO SDR 21 pipes**  
(female ends for solvent welding)

Part No.	DN	d	K-Factor	F.S. l/s
TFIV20B	15	20	462,04	0,88
TFIV25B	20	25	272,89	1,57
TFIV32B	25	32	157,86	2,45
TFIV40B	32	40	101,60	4,02
TFIV50B	40	50	63,72	6,28
TFIV20D	15	20	462,04	0,88
TFIV25D	20	25	272,89	1,57
TFIV32D	25	32	157,86	2,45
TFIV40D	32	40	101,60	4,02
TFIV50D	40	50	63,72	6,28

PVC Glue-on Fittings				
Part No.	DN	d	K-Factor	F.S. l/s
WAIV063	50	63	on request	12,54
WAIV075	65	75	on request	17,73
WAIV090	80	90	on request	25,58
WAIV110	100	110	on request	38,18
WAIV125	110	125	on request	49,44
WAIV140	125	140	on request	62,05
WAIV160	150	160	on request	80,98
WAIV200	180	200	on request	126,67
WAIV225	200	225	on request	160,40
WAIV250	225	250	on request	198,46
WAIV280	250	280	on request	248,60
WAIV315	280	315	on request	315,19

**BSP Female Threaded PVC Tee Fittings for BS PN12 pipes**  
(parallel threaded female ends)

Part No.	DN	R	K-Factor	F.S. l/s
TFFV20B	15	1/2"	462,04	0,88
TFFV25B	20	3/4"	272,89	1,57
TFFV32B	25	1"	157,86	2,45
TFFV40B	32	1 1/4"	101,60	4,02
TFFV50B	40	1 1/2"	63,72	6,28
TFFV20D	15	1/2"	462,04	0,88
TFFV25D	20	3/4"	272,89	1,57
TFFV32D	25	1"	157,86	2,45
TFFV40D	32	1 1/4"	101,60	4,02
TFFV50D	40	1 1/2"	63,72	6,28

**ISO Metric Clamp Saddles for ISO SDR 21 pipes**  
(PN10 up to d 90mm, PN12,5 from d 110mm)

Part No.	DN	d	K-Factor	F.S. l/s
SCIC063BVC	50	63	39,88	12,54
SCIC075BVC	65	75	28,19	17,73
SCIC090BVC	80	90	19,55	25,58
SCIC110BVC	100	110	13,10	38,18
SCIC125BVC	110	125	10,11	49,44
SCIC140BVC	125	140	5,24	62,05
SCIC160BVC	150	160	4,01	80,98
SCIC200BVC	180	200	2,57	126,67
SCIC225BVC	200	225	2,03	160,40
SCIC063DVC	50	63	39,88	12,54
SCIC075DVC	65	75	28,19	17,73
SCIC090DVC	80	90	19,55	19,55
SCIC110DVC	100	110	13,10	38,18
SCIC125DVC	110	125	10,11	49,44
SCIC140DVC	125	140	5,24	62,05
SCIC160DVC	150	160	4,01	80,98
SCIC200DVC	180	200	2,57	126,67
SCIC225DVC	200	225	2,03	160,40
SMIC250IVC	225	250	1,64	198,46
SMIC280IVC	250	280	1,31	248,60
SMIC315IVC	280	315	1,03	315,19

**BS Solvent Welding PVC Tee Fittings for BS PN12 pipes**  
(female ends for solvent welding)

Part No.	DN	d	K-Factor	F.S. l/s
TFLV20B	15	1/2"	462,04	0,88
TFLV25B	20	3/4"	272,89	1,57
TFLV32B	25	1"	157,86	2,45
TFLV40B	32	1 1/4"	101,60	4,02
TFLV50B	40	1 1/2"	63,72	6,28
TFLV20D	15	1/2"	462,04	0,88
TFLV25D	20	3/4"	272,89	1,57
TFLV32D	25	1"	157,86	2,45
TFLV40D	32	1 1/4"	101,60	4,02
TFLV50D	40	1 1/2"	63,72	6,28

**NPT Female Threaded PVC Tee Fittings for ASTM SCH. 80 pipes**  
(NPT threaded female ends)

Part No.	SIZE	R	K-Factor	F.S. l/s
TFNV20B	0.50"	1/2"	462,04	0,88
TFNV25B	0.75"	3/4"	272,89	1,57
TFNV32B	1.00"	1"	157,86	2,45
TFNV40B	1.25"	1 1/4"	101,60	4,02
TFNV50B	1.50"	1 1/2"	63,72	6,28
TFNV20D	0.50"	1/2"	462,04	0,88
TFNV25D	0.75"	3/4"	272,89	1,57
TFNV32D	1.00"	1"	157,86	2,45
TFNV40D	1.25"	1 1/4"	101,60	4,02
TFNV50D	1.50"	1 1/2"	63,72	6,28

**ASTM SCH. 80 PVC Tee Fittings for ASTM SCH. 80 pipes**  
(female ends for solvent welding)

Part No.	SIZE	d	K-Factor	F.S. l/s
TFAV20B	0.50"	0,85"	462,04	0,88
TFAV25B	0.75"	1,06"	272,89	1,57
TFAV32B	1.00"	1,33"	157,86	2,45
TFAV40B	1.25"	1,67"	101,60	4,02
TFAV50B	1.50"	1,91"	63,72	6,28
TFAV20D	0.50"	0,85"	462,04	0,88
TFAV25D	0.75"	1,06"	272,89	1,57
TFAV32D	1.00"	1,33"	157,86	2,45
TFAV40D	1.25"	1,67"	101,60	4,02
TFAV50D	1.50"	1,91"	63,72	6,28

**BS Clamp Saddles for BS PN12 pipes**

Part No.	DN	d	K-Factor	F.S. l/s
SCLC2.0BVM	50	2"	43,50	11,49
SCLC3.0BVM	80	3"	20,04	24,95
SCLC4.0BVM	100	4"	12,17	41,10
SCLC6.0BVM	150	6"	3,64	89,19
SCLC8.0BVM	200	8"	2,10	154,74
SCLC2.0DVM	50	2"	43,50	11,49
SCLC3.0DVM	80	3"	20,04	24,95
SCLC4.0DVM	100	4"	12,17	41,10
SCLC6.0DVM	150	6"	3,64	89,19
SCLC8.0DVM	200	8"	2,10	154,74

**ASTM SCH. 80 Clamp Saddles for ASTM SCH. 80 pipes**

Part No.	SIZE	d	K-Factor	F.S. l/s
SCAC2.0BVM	2.00"	2,375"	53,93	9,27
SCAC2.5BVM	2.50"	2,875"	37,67	13,27
SCAC3.0BVM	3.00"	3,500"	24,06	20,78
SCAC4.0BVM	4.00"	4,500"	17,84	28,03
SCAC5.0BVM	5.00"	5,520"	13,77	36,31
SCAC6.0BVM	6.00"	6,625"	3,93	82,57
SCAC8.0BVM	8.00"	8,625"	2,24	145,00
SCAC2.0DVM	2.00"	2,375"	53,93	9,27
SCAC2.5DVM	2.50"	2,875"	37,67	13,27
SCAC3.0DVM	3.00"	3,500"	24,06	20,78
SCAC4.0DVM	4.00"	4,500"	17,84	28,03
SCAC5.0DVM	5.00"	5,520"	13,77	36,31
SCAC6.0DVM	6.00"	6,625"	3,93	82,57
SCAC8.0DVM	8.00"	8,625"	2,24	145,00



## Installation on C-PVC pipes

ISO Metric CPVC Tee Fittings for ISO SDR 21 pipes (female ends for solvent welding)				
Part No.	DN	d	K-Factor	F.S. l/s
TFIC20B	15	20	462,04	0,88
TFIC25B	20	25	272,89	1,57
TFIC32B	25	32	157,86	2,45
TFIC40B	32	40	101,60	4,02
TFIC50B	40	50	63,72	6,28
TFIC20D	15	20	462,04	0,88
TFIC25D	20	25	272,89	1,57
TFIC32D	25	32	157,86	2,45
TFIC40D	32	40	101,60	4,02
TFIC50D	40	50	63,72	6,28

CPVC Glue-on Fittings				
Part No.	DN	d	K-Factor	F.S. l/s
WAIC063	50	63	on request	
WAIC075	65	75	on request	
WAIC090	80	90	on request	
WAIC110	100	110	on request	
WAIC125	110	125	on request	
WAIC140	125	140	on request	
WAIC160	150	160	on request	
WAIC200	180	200	on request	
WAIC225	200	225	on request	
WAIC250	225	250	on request	
WAIC280	250	280	on request	
WAIC315	280	315	on request	

ISO Clamp Saddles for ISO SDR 21 pipes				
Part No.	DN	d	K-Factor	F.S. l/s
SCIC063BVC	50	63	39,88	12,54
SCIC075BVC	65	75	28,19	17,73
SCIC090BVC	80	90	19,55	25,58
SCIC110BVC	100	110	13,10	38,18
SCIC125BVC	110	125	10,11	49,44
SCIC140BVC	125	140	5,24	62,05
SCIC160BVC	150	160	4,01	80,98
SCIC200BVC	180	200	2,57	126,67
SCIC225BVC	200	225	2,03	160,40
SCIC063DVC	50	63	39,88	12,54
SCIC075DVC	65	75	28,19	17,73
SCIC090DVC	80	90	19,55	25,58
SCIC110DVC	100	110	13,10	38,18
SCIC125DVC	110	125	10,11	49,44
SCIC140DVC	125	140	5,24	62,05
SCIC160DVC	150	160	4,01	80,98
SCIC200DVC	180	200	2,57	126,67
SCIC225DVC	200	225	2,03	160,40
SMIC250IVC	225	250	1,64	198,46
SMIC280IVC	250	280	1,30	248,60
SMIC315IVC	280	315	1,03	315,19

## Installation on PP pipes

ISO Metric PP Tee Fittings for ISO SDR 11 pipes (female ends for socket welding)				
Part No.	DN	d	K-Factor	F.S. l/s
TFIM20B	15	20	510,01	0,88
TFIM25B	20	25	321,51	1,57
TFIM32B	25	32	192,77	2,45
TFIM40B	32	40	124,34	4,02
TFIM50B	40	50	79,18	6,28
TFIM20D	15	20	510,01	0,88
TFIM25D	20	25	321,51	1,57
TFIM32D	25	32	192,77	2,45
TFIM40D	32	40	124,34	4,02
TFIM50D	40	50	79,18	6,28

BSP Female Threaded PP Tee Fittings for BS pipes (parallel threaded female ends)				
Part No.	DN	R	K-Factor	F.S. l/s
TFFM20B	15	1/2"	510,01	0,88
TFFM25B	20	3/4"	321,51	1,57
TFFM32B	25	1"	192,77	2,45
TFFM40B	32	1 1/4"	124,34	4,02
TFFM50B	40	1 1/2"	79,18	6,28
TFFM20D	15	1/2"	510,01	0,88
TFFM25D	20	3/4"	321,51	1,57
TFFM32D	25	1"	192,77	2,45
TFFM40D	32	1 1/4"	124,34	4,02
TFFM50D	40	1 1/2"	79,18	6,28

**ISO Clamp Saddles for ISO SDR 21 pipes**

Part No.	DN	d	K-Factor	F.S. l/s
SCIC063BME	50	63	42,40	11,79
SCIC075BME	65	75	29,86	16,75
SCIC090BME	80	90	20,71	24,14
SCIC110BME	100	110	13,84	36,12
SCIC125BME	110	125	10,68	46,83
SCIC140BME	125	140	5,50	59,12
SCIC160BME	150	160	4,23	76,75
SCIC200BME	180	200	2,71	119,99
SCIC225BME	200	225	2,14	151,79
SCIC063DME	50	63	42,40	11,79
SCIC075DME	65	75	29,86	16,75
SCIC090DME	80	90	20,71	24,14
SCIC110DME	100	110	13,84	36,12
SCIC125DME	110	125	10,68	46,83
SCIC140DME	125	140	5,50	59,12
SCIC160DME	150	160	4,23	76,75
SCIC200DME	180	200	2,71	119,99
SCIC225DME	200	225	2,14	151,79
SMIC250IME	225	250	1,73	187,83
SMIC280IME	250	280	1,38	235,53
SMIC315IME	280	315	1,09	298,07

**PP Glue-on Fittings**

Part No.	DN	d	K-Factor	F.S. l/s
WAIM063	50	63	on request	
WAIM075	65	75	on request	
WAIM090	80	90	on request	
WAIM110	100	110	on request	
WAIM125	110	125	on request	
WAIM140	125	140	on request	
WAIM160	150	160	on request	
WAIM200	180	200	on request	
WAIM225	200	225	on request	
WAIM250	225	250	on request	
WAIM280	250	280	on request	
WAIM315	280	315	on request	

**NPT Female Threaded PP Tee Fittings for ASTM SCH.80 pipes**

(NPT threaded female ends)

Part No.	DN	R	K-Factor	F.S. l/s
TFNM20B	0.50"	1/2"	510,01	0,88
TFNM25B	0.75"	3/4"	321,51	1,57
TFNM32B	1.00"	1"	192,77	2,45
TFNM40B	1.25"	1 1/4"	124,34	4,02
TFNM50B	1.50"	1 1/2"	79,18	6,28
TFNM20D	0.50"	1/2"	510,01	0,88
TFNM25D	0.75"	3/4"	321,51	1,57
TFNM32D	1.00"	1"	192,77	2,45
TFNM40D	1.25"	1 1/4"	124,34	4,02
TFNM50D	1.50"	1 1/2"	79,18	6,28

**ASTM SCH. 80 Clamp Saddles for ASTM SCH. 80 pipes**

Part No.	SIZE	d	K-Factor	F.S. l/s
SCAC2.0BME	2.00"	2,375"	53,93	9,27
SCAC2.5BME	2.50"	2,875"	37,67	13,27
SCAC3.0BME	3.00"	3,500"	24,06	20,78
SCAC4.0BME	4.00"	4,500"	13,77	36,31
SCAC5.0BME	5.00"	5,520"	8,68	57,57
SCAC6.0BME	6.00"	6,625"	6,06	82,57
SCAC8.0BME	8.00"	8,625"	3,45	145,00
SCAC2.0DME	2.00"	2,375"	53,93	9,27
SCAC2.5DME	2.50"	2,875"	37,67	13,27
SCAC3.0DME	3.00"	3,500"	24,06	20,78
SCAC4.0DME	4.00"	4,500"	13,77	36,31
SCAC5.0DME	5.00"	5,520"	5,64	57,57
SCAC6.0DME	6.00"	6,625"	3,99	82,57
SCAC8.0DME	8.00"	8,625"	2,24	145,00

## Installation on PVDF pipes

**ISO Metric PVDF Tee Fittings for ISO SDR 33 pipes**  
(female ends for socket welding)

Part No.	DN	d	K-Factor	F.S. l/s
TFIF20B	15	20	510,01	0,88
TFIF25B	20	25	294,29	1,57
TFIF32B	25	32	178,60	2,45
TFIF40B	32	40	105,74	4,02
TFIF50B	40	50	67,60	6,28
TFIF20D	15	20	510,01	0,88
TFIF25D	20	25	294,29	1,57
TFIF32D	25	32	178,60	2,45
TFIF40D	32	40	105,74	4,02
TFIF50D	40	50	67,60	6,28

**ISO Clamp Saddles for ISO SDR 33 pipes**

Part No.	DN	d	K-Factor	F.S. l/s
SCIC063BF	50	63	37,20	13,44
SCIC075BF	65	75	26,06	19,19
SCIC090BF	80	90	18,09	27,64
SCIC110BF	100	110	12,09	41,34
SCIC125BF	110	125	9,38	53,30
SCIC140BF	125	140	4,84	67,08
SCIC160BF	150	160	3,70	87,77
SCIC200BF	180	200	2,37	136,89
SCIC225BF	200	225	1,87	173,68
SCIC063DF	50	63	37,20	13,44
SCIC075DF	65	75	26,06	19,19
SCIC090DF	80	90	18,09	27,64
SCIC110DF	100	110	12,09	41,34
SCIC125DF	110	125	9,38	53,30
SCIC140DF	125	140	4,84	67,08
SCIC160DF	150	160	3,70	87,77
SCIC200DF	180	200	2,37	136,89
SCIC225DF	200	225	1,87	173,68

## Installation on PE pipes

**ISO Metric PVC Tee Fittings for PE SDR 11 pipes**  
(PE end connectors for electrofusion or butt welding)

Part No.	DN	d	K-Factor	F.S. l/s
TFIV20BE	15	20	510,01	0,88
TFIV25BE	20	25	318,30	1,57
TFIV32BE	25	32	194,27	2,45
TFIV40BE	32	40	122,80	4,02
TFIV50BE	40	50	78,79	6,28
TFIV20DE	15	20	510,01	0,88
TFIV25DE	20	25	318,30	1,57
TFIV32DE	25	32	194,27	2,45
TFIV40DE	32	40	122,80	4,02
TFIV50DE	40	50	78,79	6,28

**ISO Clamp Saddles for PE SDR 11 pipes**

Part No.	DN	d	K-Factor	F.S. l/s
SCIC063BME	50	63	49,53	10,09
SCIC075BME	65	75	34,67	14,42
SCIC090BME	80	90	23,50	21,27
SCIC110BME	100	110	16,07	31,11
SCIC125BME	110	125	12,48	40,06
SCIC140BME	125	140	6,41	50,68
SCIC160BME	150	160	4,95	65,55
SCIC200BME	180	200	3,17	102,55
SCIC225BME	200	225	2,50	129,80
SCIC063DME	50	63	49,53	10,09
SCIC075DME	65	75	34,67	14,42
SCIC090DME	80	90	23,50	21,27
SCIC110DME	100	110	16,07	16,07
SCIC125DME	110	125	12,48	40,06
SCIC140DME	125	140	6,41	50,68
SCIC160DME	150	160	4,95	65,55
SCIC200DME	180	200	3,17	102,55
SCIC225DME	200	225	2,50	129,80
SMIC250IVC	225	250	2,01	161,83
SMIC280IVC	250	280	1,61	201,29
SMIC315IVC	280	315	1,27	254,96

**PE Glue-on Fittings**

Part No.	DN	d	K-Factor	F.S. l/s
WAIE063	50	63	on request	
WAIE075	65	75	on request	
WAIE090	80	90	on request	
WAIE110	100	110	on request	
WAIE125	110	125	on request	
WAIE140	125	140	on request	
WAIE160	150	160	on request	
WAIE200	180	200	on request	
WAIE225	200	225	on request	
WAIE250	225	250	on request	
WAIE280	250	280	on request	
WAIE315	280	315	on request	

## Special Installation on DN 250 and DN 300 pipes

PVC Wafer Fittings				
Part No.	DN	d	K-Factor	F.S. l/s
WVIC280B	250	280	on request	
WVIC315B	300	315	on request	
WVIC280D	250	280	on request	
WVIC315D	300	315	on request	

PP Wafer Fittings				
Part No.	DN	d	K-Factor	F.S. l/s
WFIC280B	250	280	on request	
WFIC315B	300	315	on request	
WFIC280D	250	280	on request	
WFIC315D	300	315	on request	

## Metal Fittings

316L SS Threaded Tees (BSP Female Threads)				
Part No.	DN	R	K-Factor	F.S. l/s
TFFX25	20	3/4"	308,21	1,57
TFFX32	25	1"	177,84	2,45
TFFX40	32	1 1/4"	88,85	4,02

Metal Strap-on Saddles mounted on Cast Iron pipes				
Part No.	DN	K-Factor	F.S. l/s	
SZIC080I	80	20,22	24,72	
SZIC100I	100	12,99	38,50	
SZIC125I	125	5,31	61,20	
SZIC150I	150	3,67	88,55	
SZIC200I	200	2,03	160,40	
SZIC250I	250	1,31	248,60	
SZIC300I	300	0,90	362,76	
SZIC350I	350	0,67	480,66	
SZIC400I	400	0,53	620,20	
SZIC450I	450	0,40	801,10	

Metal Strap-on Saddles mounted on Other Metal pipes				
Part No.	DN	K-Factor	F.S. l/s	
SZIC080I	80	19,02	26,29	
SZIC100I	100	11,28	44,32	
SZIC125I	125	4,83	67,30	
SZIC150I	150	3,31	98,13	
SZIC200I	200	1,95	166,92	
SZIC250I	250	1,24	261,85	
SZIC300I	300	0,88	369,74	
SZIC350I	350	0,73	447,12	
SZIC400I	400	0,54	600,82	
SZIC450I	450	-----	-----	

316L SS Weld-on Adapters mounted on Cast Iron pipes				
Part No.	DN	K-Factor	F.S. l/s	
WAIXL0	40	-----	-----	
WAIXL0	50	-----	-----	
WAIXL0	60	37,23	13,43	
WAIXL0	65	-----	-----	
WAIXL0	80	20,22	24,72	
WAIXL0	100	12,99	38,50	
WAIXL0	110	-----	-----	
WAIXL0	125	5,31	61,20	
WAIXL0	150	3,67	88,55	
WAIXL0	175	-----	-----	
WAIXL0	200	2,03	160,40	
WAIXL1	225	-----	-----	
WAIXL1	250	1,31	248,60	
WAIXL1	300	0,90	362,84	
WAIXL1	350	0,68	480,77	
WAIXL1	400	0,53	620,35	
WAIXL1	450	0,40	801,28	
WAIXL1	500	0,34	961,54	
WAIXL1	600	0,23	1373,63	

316L SS Weld-on Adapters mounted on Other Metal pipes				
Part No.	DN	K-Factor	F.S. l/s	
WAIXL0	40	53,74	9,30	
WAIXL0	50	43,60	11,47	
WAIXL0	60	-----	-----	
WAIXL0	65	26,22	19,07	
WAIXL0	80	19,02	26,29	
WAIXL0	100	11,28	44,32	
WAIXL0	110	-----	-----	
WAIXL0	125	4,83	67,30	
WAIXL0	150	3,31	98,13	
WAIXL0	175	-----	-----	
WAIXL0	200	1,95	166,92	
WAIXL1	225	-----	-----	
WAIXL1	250	1,24	261,85	
WAIXL1	300	0,88	369,82	
WAIXL1	350	0,73	447,23	
WAIXL1	400	0,54	600,96	
WAIXL1	450	-----	-----	
WAIXL1	500	0,34	961,54	
WAIXL1	600	-----	-----	

---

**Correction formula for K-Factor calculation according to real internal diameter:**

$$K\text{-Factor\_NEW} = (K\text{-Factor} \times ID^2) / ID\text{-NEW}^2$$

*where:*

**ID** = Value in the table for the internal diameter (in mm)

**ID\_NEW** = New value for the real internal diameter (always in mm)

**K-Factor** = Value in the table

**K-Factor\_NEW** = New K-Factor value for the specified internal diameter

**EXAMPLE:**

Nominal Pipe Size PVC (DN) = 100 mm

New Internal Diameter = 104 mm

*Using the formula:*  $K\text{-Factor\_NEW} = (13,10 \times 100^2) / 104^2 = 12,11$

**K-factor calculation with a different full scale (Standard 5 m/sec).**

$$K\text{-Factor\_NEW} = (K\text{-Factor} \times F.S. ) / F.S.\_NEW$$

*Where:*

**K-Factor** = Value in the table

**F.S.** = full scale standard 5 m/sec

**F.S.\_NEW** = New value of full scale

**K-Factor\_NEW** = New K-Factor value for the specified full scale

**EXAMPLE:**

F.S. (Standard) = 5 m/sec

F.S.\_NEW = 8 m/sec

Nominal Pipe Size PVC (DN) = 100 mm

*Using the formula:*  $K\text{-Factor\_NEW} = (13,10 \times 5) / 8 = 8,19$

## 11. Ordering Data

### FLOWX3 NEW F9.63M.XX

Part No.	Power supply	Length	Body	Electrodes	O-rings	Enclosure
F9.60M.09	12-24 VDC	L0	316L SS/PVDF	316L SS	EPDM	IP65
F9.60M.10	12-24 VDC	L0	316L SS/PVDF	316L SS	FPM	IP65
F9.60M.11	12-24 VDC	L1	316L SS/PVDF	316L SS	EPDM	IP65
F9.60M.12	12-24 VDC	L1	316L SS/PVDF	316L SS	FPM	IP65
F9.60M.33	12-24 VDC	L0	CuNi/PVDF	CuNi	EPDM	IP65
F9.60M.34	12-24 VDC	L0	CuNi/PVDF	CuNi	FPM	IP65
F9.60M.35	12-24 VDC	L1	CuNi/PVDF	CuNi	EPDM	IP65
F9.60M.36	12-24 VDC	L1	CuNi/PVDF	CuNi	FPM	IP65
F9.60M.38	12-24 VDC	L0	316L SS/PEEK	316L SS	FPM	IP65
F9.60M.40	12-24 VDC	L1	316L SS/PEEK	316L SS	FPM	IP65

### Spare Parts

#### Mechanical Replacements

Item	Part No.	Name	Description
1	F9.SP2	Cover	PC front cover, 3 LED
2	F3.KC1	Magmeter Compact mounting kit	Plastic adapter with gasket, compact cap, locking ring and 4 fixing screws
3	F9.SP4.1	PG 13.5	PG 13.5 Cable Gland for Compact kit
3	F9.SP4.2	PG 11	PG 11 Cable Gland for Compact kit
4	F3.SP3.1	O-Rings	EPDM Sensor body O-Rings
4	F3.SP3.2	O-Rings	FPM Sensor body O-Rings

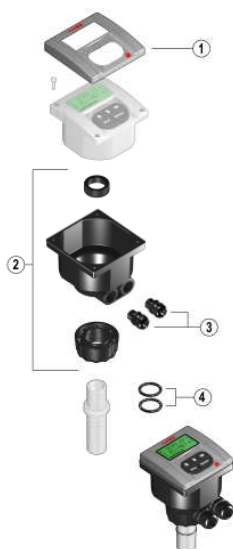

## Electronic Replacements

Item	Part No.	Name	Description
1	F9.60M.SP1	Electronic device	Magmeter electronic device with display, 4-20mA output, 2 relay output and 1 open collector output for mono-directional sensor
2	F3.60M.SP09	Magmeter mono-directional flow sensor	316L SS/PVDF body - EPDM O-Rings - L0 length
2	F3.60M.SP10	Magmeter mono-directional flow sensor	316L SS/PVDF body - FPM O-Rings - L0 length
2	F3.60M.SP11	Magmeter mono-directional flow sensor	316L SS/PVDF body - EPDM O-Rings - L1 length
2	F3.60M.SP12	Magmeter mono-directional flow sensor	316L SS/PVDF body - FPM O-Rings - L1 length
2	F3.60M.SP13	Magmeter mono-directional flow sensor	CuNi/PVDF body - EPDM O-Rings - L0 length
2	F3.60M.SP14	Magmeter mono-directional flow sensor	CuNi/PVDF body - FPM O-Rings - L0 length
2	F3.60M.SP15	Magmeter mono-directional flow sensor	CuNi/PVDF body - EPDM O-Rings - L1 length
2	F3.60M.SP16	Magmeter mono-directional flow sensor	CuNi/PVDF body - FPM O-Rings - L1 length
2	F3.60M.SP17	Magmeter mono-directional flow sensor	316L SS/PEEK body - FPM O-Rings - L0 length
2	F3.60M.SP18	Magmeter mono-directional flow sensor	316L SS/PEEK body - FPM O-Rings - L1 length

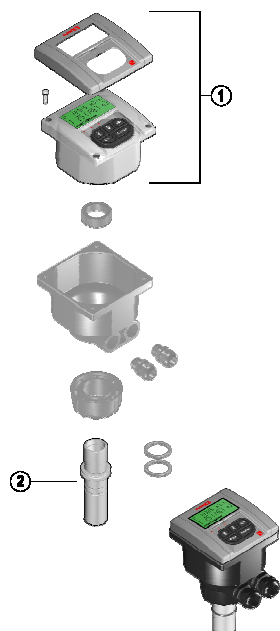

**F.I.P.** Formatura Iniezione Polimeri S.p.A.  
Loc. Pian di Parata, 16015 Casella (GE) – Italy  
Tel +39 010 96211 – Fax +39 010 9621209

**[www.flsnet.it](http://www.flsnet.it)**