



F9.00.L Flow Monitor and Transmitter with ASEC function

INSTRUCTION MANUAL

EN 10-11

Table of Contents

1. Introduction.....	3
1.1. Safety Instructions.....	3
1.2. Unpacking.....	3
2. Description.....	4
2.1. Design.....	4
2.2. Technical Features.....	4
2.3. Connection to FlowX3 Sensors.....	4
3. Specifications.....	5
3.1. Technical Data.....	5
3.2. Dimensions.....	6
4. Installation.....	7
4.1. Panel Installation.....	7
4.2. Wall Installation.....	8
4.3. Compact Installation.....	8
4.4. Wiring.....	9
5. Operational Overview.....	12
5.1. Keypad Functions.....	12
5.2. General Operation Flowchart.....	12
6. View Level.....	14
7. Menu Directory Level.....	14
7.1. Free access (no password required).....	15
7.2. Password protected access.....	15

8. Menu and Edit Level.....	16
8.1. Calibration Menu.....	16
8.1.1. Unit.....	16
8.1.2. K-Factor.....	17
8.1.3. Material.....	17
8.1.4. Size.....	18
8.2. Output Menu.....	18
8.2.1. 4 – 20mA Output.....	19
8.2.2. S.S.R. Output (OPT).....	19
8.2.2.1. S.S.R. Output (OPT): MIN mode.....	20
8.2.2.2. S.S.R. Output (OPT): MAX mode.....	20
8.2.2.3. S.S.R. Output (OPT): PULSE mode.....	21
8.2.2.4. S.S.R. Output (OPT): WINDOW mode.....	21
8.2.2.5. S.S.R. Output (OPT): FREQUENCY mode.....	22
8.3. Simulation Menu.....	23
8.3.1. Test 4 – 20mA Loop.....	23
8.3.2. Test S.S.R. Output (OPT).....	23
8.4. Options Menu.....	24
8.4.1. Contrast.....	24
8.4.2. Filter.....	25
8.4.3. Backlight.....	25
8.4.4. Flow Decimal Point.....	26
8.4.5. Total Decimal Point.....	26
8.4.6. Loop Adjust 4mA.....	27
8.4.7. Loop Adjust 20mA.....	27
8.4.8. Menu PWD.....	28
8.4.9. Restot PWD.....	28
8.4.10. K-Factor Calculate.....	29
8.4.11. ASEC.....	29
9. Troubleshooting.....	30
9.1. Display messages.....	30
10. Ordering Data.....	31

1. Introduction



CAUTION

1.1. Safety Instructions

General Statements

- ❑ Do not install and service the instrument without following the Instruction Manual.
- ❑ This unit is designed to be connected to other instruments which can be hazardous if used improperly. Read and follow all associated instrument manuals before using with this instrument.
- ❑ Unit installation and wiring connections should only be performed by qualified staff.
- ❑ Do not modify product construction.

Installation and Commissioning Statements

- ❑ Remove power to the instrument before wiring input and output connections.
- ❑ Do not exceed maximum specifications using the instrument.
- ❑ To clean the unit, use only chemical compatible products.

1.2. Unpacking

Please verify that the product is complete and without any damage. The following items must be included:

- F9.00.L Flow Monitor and Transmitter
- Instruction Manual for F9.00.L Flow Monitor and Transmitter
- Instruction Manual for F3.00 Flow Sensor (only for F9.00.XX.L Compact Flow Monitor and Transmitter)

2. Description

2.1. Design

The FLS FlowX3 F9.00.L Flow Monitor and Transmitter is designed to convert the signal from all FlowX3 flow sensors into a display indication and a 4...20 mA signal for long distance transmission and it also provides a programmable SSR (Solid State Relay) output. **The last introduction of ASEC function offers advanced solutions to increase linearity and accuracy of our FlowX3 measuring system (sensor + monitor).** A very high flexibility is achieved via only one packaging for compact pipe mount, panel or wall installation. Self explaining calibration menus allow a customized setup of all measuring parameters and the state of the art electronic design ensures long-term reliable and stable signals.

2.2. Technical Features

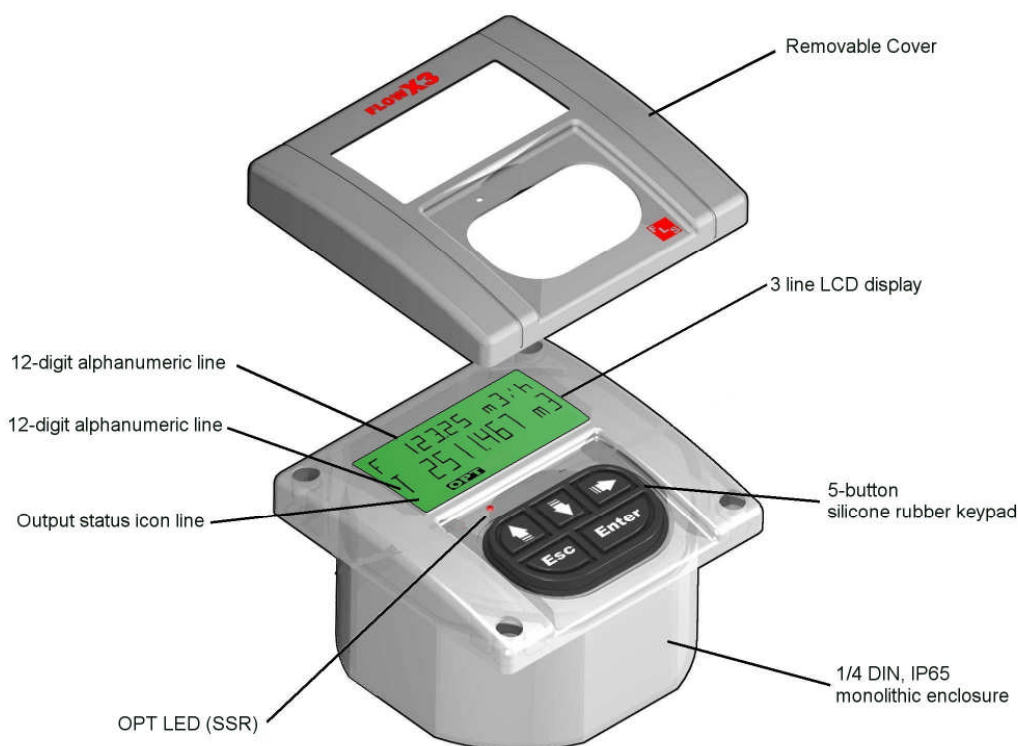

2.3. Connection to FlowX3 Sensors

FlowX3 Monitor	FlowX3 Sensors														
	F3.00.H	F3.00C	F3.01.H	F3.01.C	F3.10.H	F3.15.H*	F3.30.H*	ULF.H	ULF.R	ULF3.15*	ULF3.30*	F3.80	F111.H	F111.C	F3.60
F9.00.L	X		X		X				X				X		

* with Output Kit mounted

3. Specifications

3.1. Technical Data

General

Associated flow sensor:

- FLS FlowX3 Hall effect with frequency output

Materials:

- Case: PC
- Panel gasket: Neoprene
- Wall & Field gasket: EPDM
- Keypad: 5-button silicone rubber

Display:

- 3 line LCD: 2 x 12 alphanumeric lines + 1 icon line
- Update rate: 1 second
- Contrast: User adjustable with 5 levels

Enclosure: IP65 front

Electrical

Supply Voltage: 12 to 24 VDC \pm 10% regulated

Backlight is available with power supply \geq 12 VDC

Sensor Input (Frequency):

- Sensor power: 3,8 VDC @ $<$ 20 mA
- Range: 0.5 to 500 Hz
- Optically isolated from current loop
- Short circuit protected

Current output (Not available with backlight ON):

- 4...20 mA, isolated, fully adjustable and reversible
- Max loop impedance: 150 Ω @ 12 VDC, 330 Ω @ 18 VDC, 600 Ω @ 24 VDC

Solid-State relay output (OPT):

- User selectable as MIN alarm, MAX alarm, Pulse Out, Freq Out, Off
- No led indication
- Optically isolated, 30 mA MAX sink, 24 VAC/VDC MAX pull-up voltage
- Max pulse/min: 180 with pulse output function, 250 with Freq out function
- Hysteresis: User selectable

Environmental

Operating temperature: -10 to +70°C (14 to 158°F)

Storage temperature: -15 to +80°C (5 to 176°F)

Relative humidity: 0 to 95% non condensing

Standards and Approvals

Manufactured under ISO 9002

Manufactured under ISO 14001

CE

3.2. Dimensions

Compact Mount

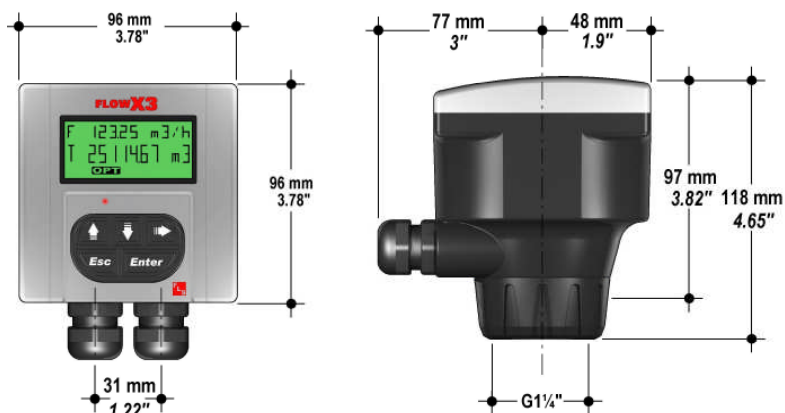

Panel Mount

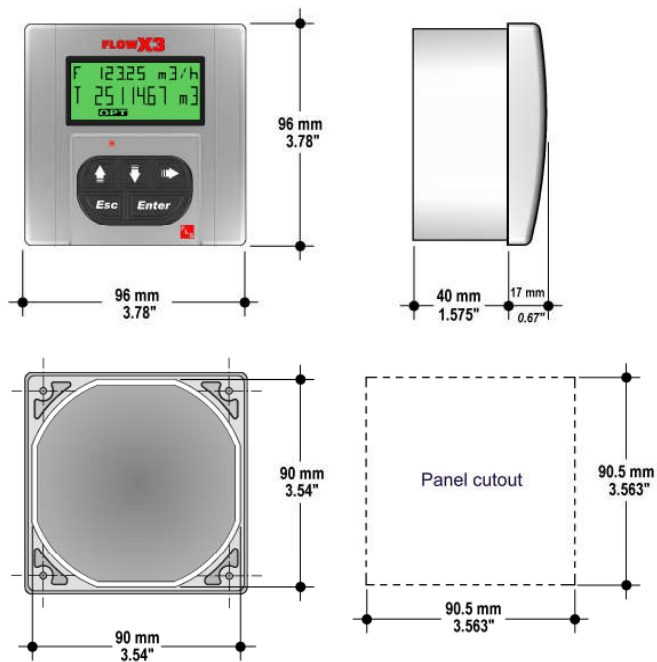

Wall Mount

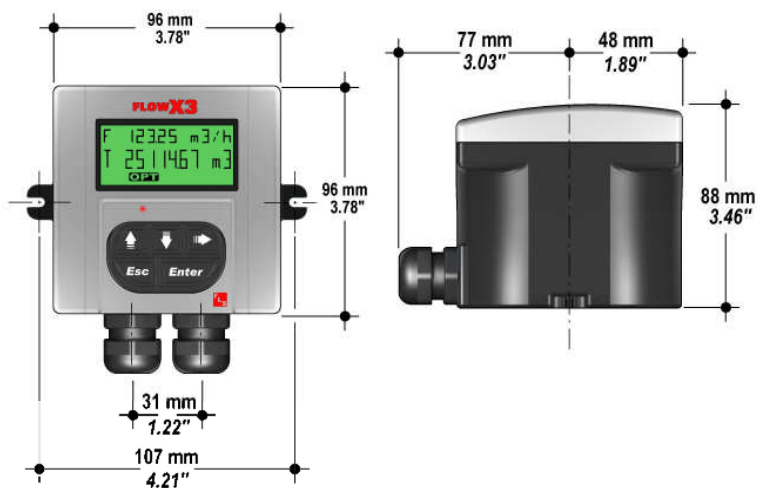

4. Installation

The flow monitor & transmitter is available just in one packaging for compact field version, panel or wall installation. The compact field version is mounted on top of the sensor using the compact mounting kit (F9.KC1), the panel version is installed using the panel mounting kit (F9.KP1.2), while the wall mounting version is fixed with the wall mounting kit (F9.KWX). The mounting kits can be ordered directly connected to the monitor or separately and then simply installed on it.

4.1. Panel Installation

The panel mounting version consists of the monitor and the mounting bracket kit F9.KP1.2 with gasket for IP65 watertight panel installation. The monitor perfectly fits into a standard ¼ DIN panel cutout.

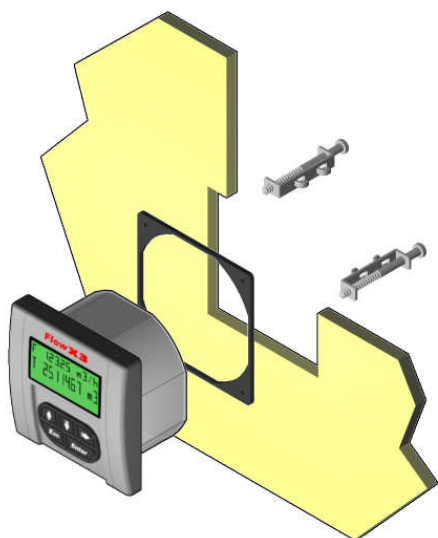

1. Cut out the panel: the F9.00.L requires a panel opening of 90,5 x 90,5 mm (3,563" x 3,563"). ¼ DIN punches are recommended, alternatively a jigsaw or another cutting tool may be used.
2. Recommended minimum clearance between panel cutouts is 28 mm (1.1") as illustrated.

3. Place gasket on the instrument and install into the panel. Be sure the panel gasket is properly seated against the panel and around the instrument case.
4. Place the panel fixing screws in the apposite seats. Screw down the screws until the instrument is perfectly fixed.

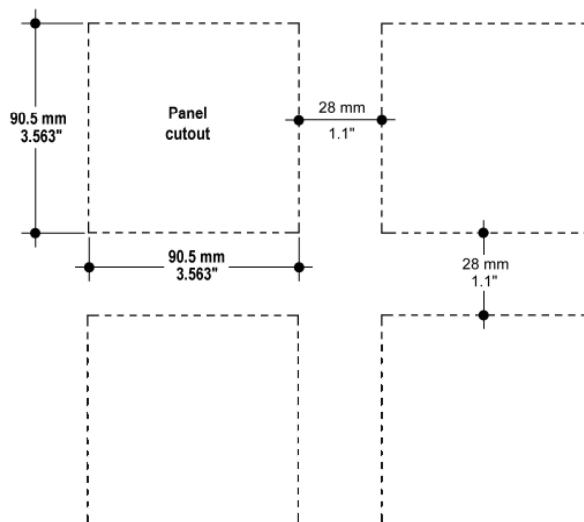

To REMOVE: Unscrew the screws and remove them from the apposite seats. Do not allow the instrument to fall out of the panel opening: it may be helpful to secure the instrument temporarily with tape from front.

4.2. Wall Installation

The wall mounting version consists of the monitor and the wall mounting kit. The F9.KW1 kit includes the plastic adapter with gasket for IP65 watertight wall installation and the fixing screws. The F9.KW2 includes also a 110/230 VAC to 24 VDC power supply directly mounted into the plastic adapter to provide a low voltage regulated output to the flow monitor.

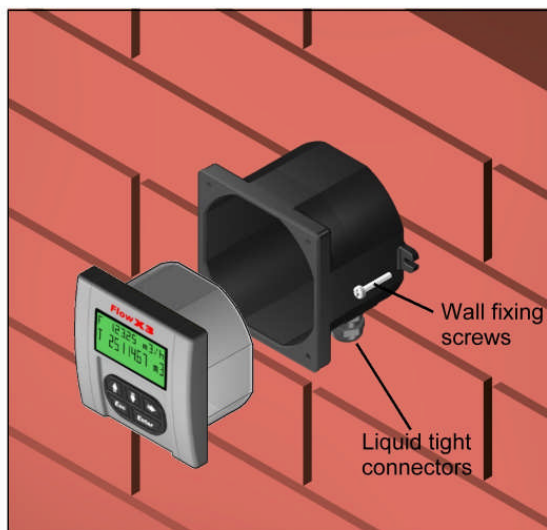

1. Fix the wall mounting kit to a solid wall using the included screws.
2. Pull the electrical cables through liquid tight connectors.
3. Make wiring connections according to wiring diagrams.
4. Secure carefully the F9.00L to the wall mounting kit using the included screws until finger tight.
5. Assemble the front cover.

4.3. Compact Installation

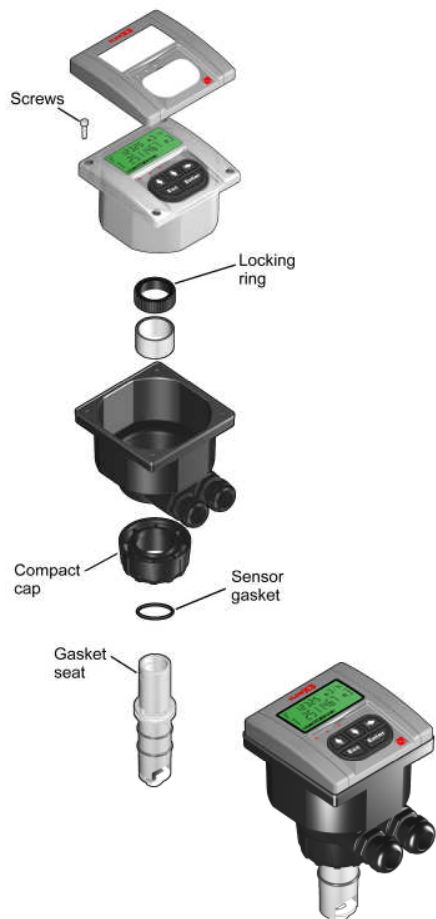

The compact mounting kit F9.KC1 includes the compact plastic adapter with gasket for IP65 watertight installation, the sensor gasket, the compact cap, the locking ring and four fixing screws.

1. Assemble the sensor gasket in the proper seat.
2. Lubricate the sensor gasket with a silicone lubricant. Do not use any petroleum based lubricant that may damage the gasket.
3. Add the compact cap to the sensor and insert the sensor into the plastic adapter making sure the alignment tabs are seated in the fitting notches.
4. Lock the sensor to the adapter: screw completely the locking ring.
5. Pull the electrical cables through liquid tight connectors.
6. Make wiring connections according to wiring diagrams.
7. Secure carefully the F9.00 to the compact mounting kit using the included screws until finger tight.
8. Assemble the front cover.

4.4. Wiring

All wiring connections to F9.00.L are made via removable terminals. Flow sensor terminals are orange, all other terminals are green.



General recommendation

- ❑ Always ensure the power supply is switched off before working on the device.
- ❑ Terminals accept 26 to 12 AWG (0.08 to 2.5 mm²)
- ❑ Strip around 10 mm (0.4") of insulation from the wire tips and tin bare ends to avoid fraying.
- ❑ Ferrules are suggested when connecting more than one wire to a single terminal.
- ❑ Remove the upper part of the terminals for an easy cabling.
- ❑ Insert wire tip or ferrule completely into the terminal and fix with the screw until finger tight.
- ❑ **Compact or Wall Installation**
Use electrical cables with the proper external diameter for the liquid tight connector:
PG11: external diameter between 2-7 mm (0.079-0.276")
PG13,5: external diameter between 5-12 mm (0.197-0.472")

Rear Terminal View

F 9.00

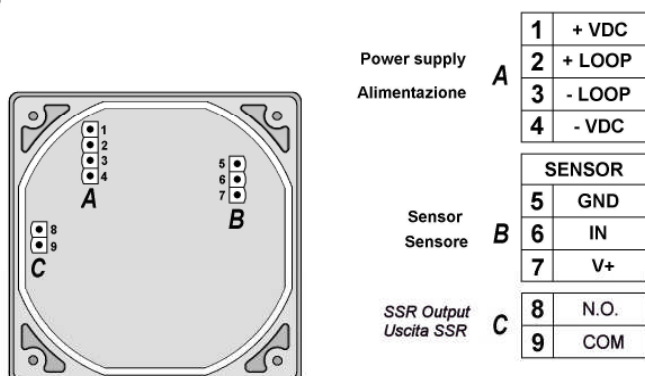

Power / Loop Wiring Diagram

Stand-alone application,
no current loop used

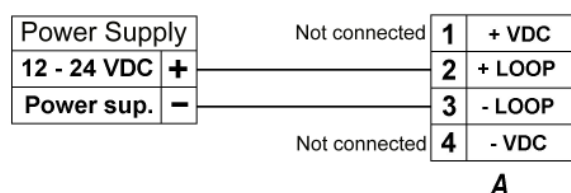

Connection to a PLC with built-in
power supply

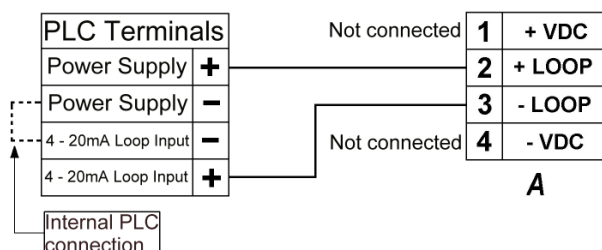

Connection to a PLC / Instrument with separate power supply

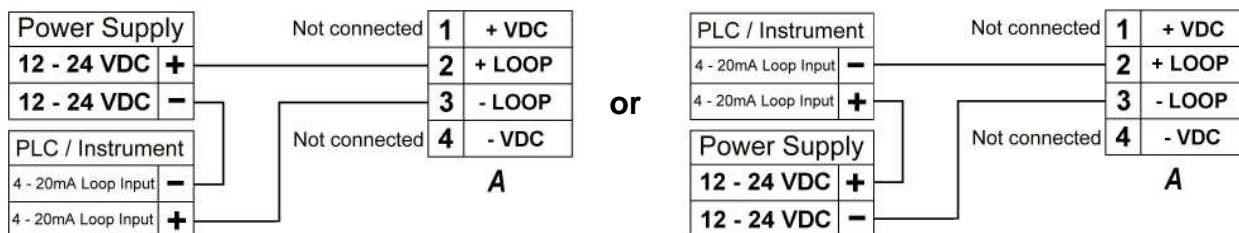

Sensor Wiring Diagram

F3.00.H IP68 or F3.01.H (compact version) or ULFXX.H flow sensor connection

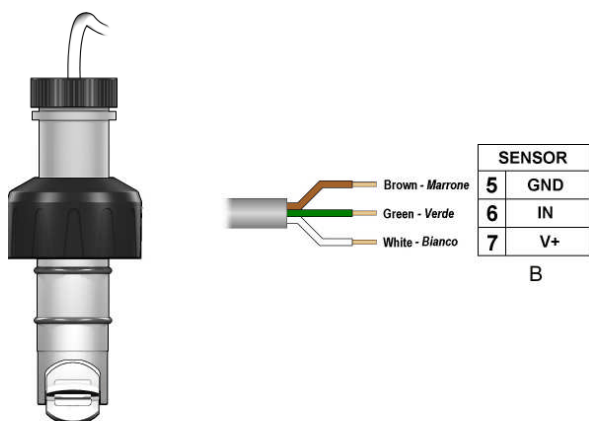

F3.00.H IP65 flow sensor connection

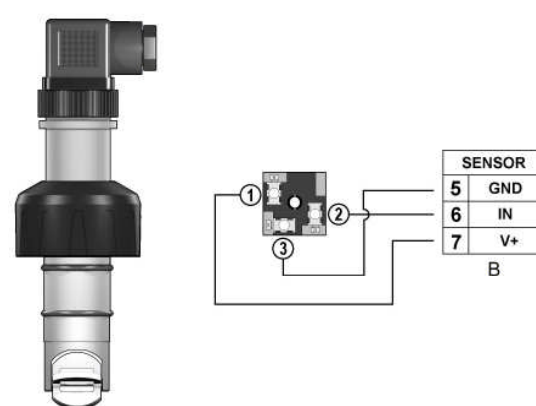

- Maximum cable length is 300 m (990 ft).
- Do not route sensor cable together with AC power wiring: electromagnetic noise may interfere with sensor signal.

Solid-State Relay Wiring Diagram

Connection to a PLC with NPN input

Connection to a PLC with PNP input

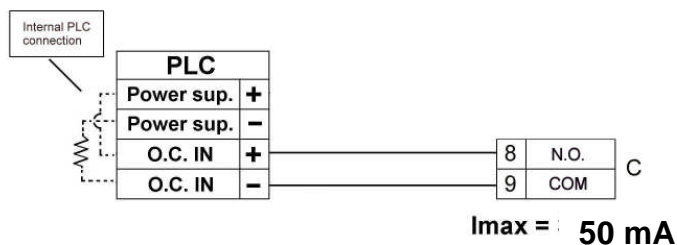
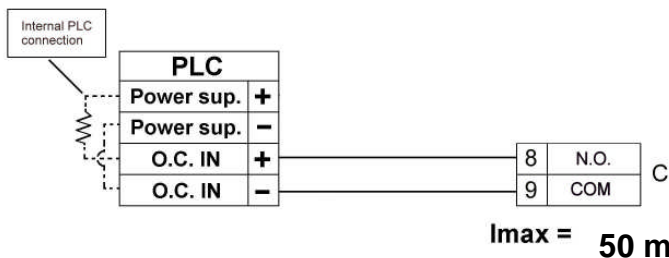

Connection to a PLC / Instrument digital input with separate Power Supply

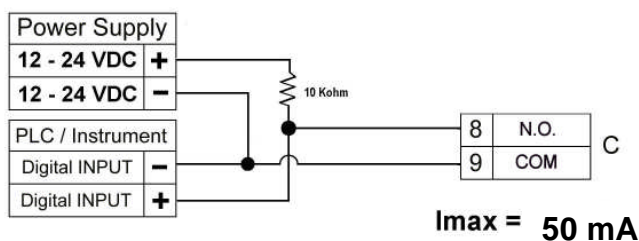

Connection to a PLC / Instrument digital input for Voltage Free Contacts (REED).

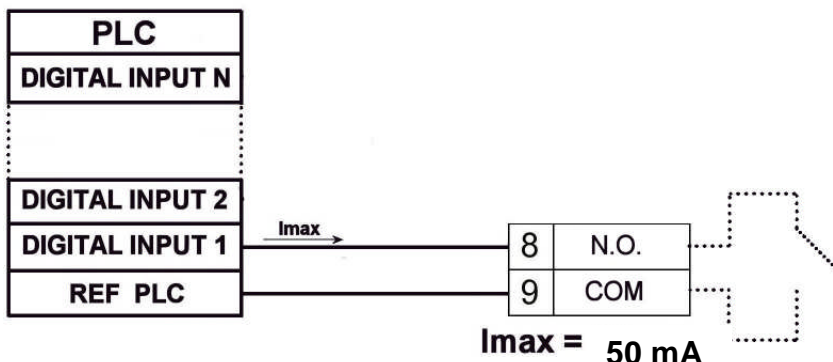

Connection to an User

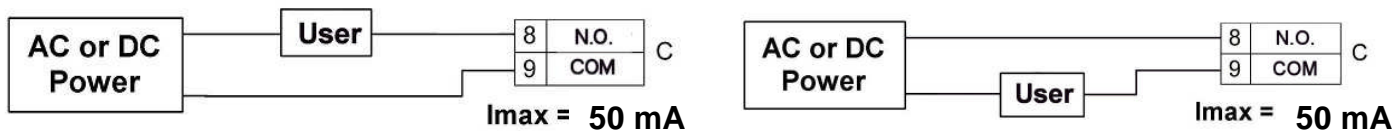

The alarm is off during normal operation and goes ON according to Relay setting.
If $I_{max} > 50 \text{ mA}$ use external Relay

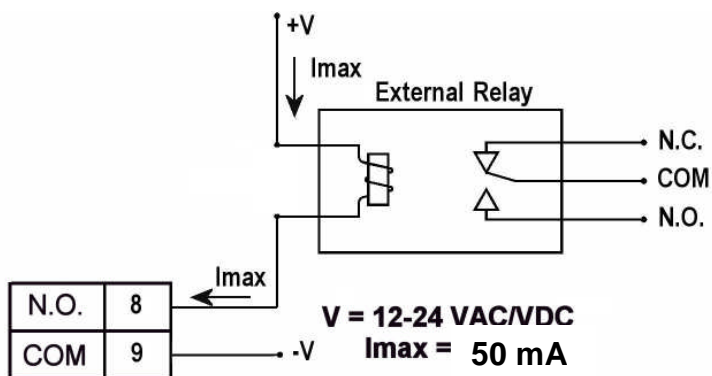

Connection to FlowX3 Instruments

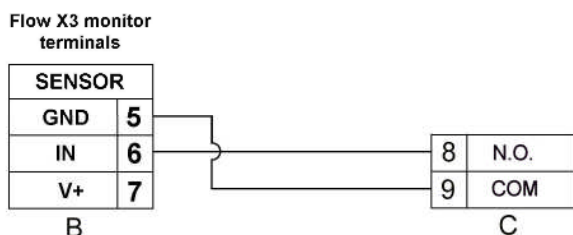

5. Operational Overview

The FlowX3 F9.00.L flow monitor and transmitter, like all members of X3 Line, features a digital display and a five-button keypad for system set-up, calibration and operation. This section contains a description of the keypad functions and the general operation flowchart of the instrument.

5.1. Keypad Functions

The five push buttons of the keypad are used to navigate display levels and modify settings.



The function of each button may change according to display level; please refer to following table:

Level	Function				
View	Scroll through items	Scroll through items	Select items marked with >	-----	Go to Menu Directory Level
Menu Directory	Scroll through items	Scroll through items	Enter menu for editing	Return to View	-----
Menu	Scroll through items	Scroll through items	Enter menu item for editing	Return to Menu Directory	-----
Edit	Modify an item or a flashing digit	Modify an item or a flashing digit	Scroll right through flashing digits	Return to Menu without saving	Save new settings

5.2. General Operation Flowchart

The F9.00.L flow monitor and transmitter features four different levels as shown in the following flowchart illustrating the basic navigation concepts.

- ❑ **View Level:** this is the default level. After instrument set-up, all measured values and status of outputs will be available. Refer to section **6. View Level** for details.
- ❑ **Menu Directory Level:** there are two different Menu Directories for different set-up and calibration. Refer to section **7. Menu Directory Level** for details. Access to this level can be free or password protected. Entering the correct password allows direct access to next levels and to all editable items in all menus, until a return to View Level.
- ❑ **Menu Level:** the current setting for each item in a Menu can be viewed and selected for editing at this level.
- ❑ **Edit Level:** all instrument parameters can be set, modified and saved at this level. Refer to section **8. Menu and Edit Levels** for details.

Operation Flowchart

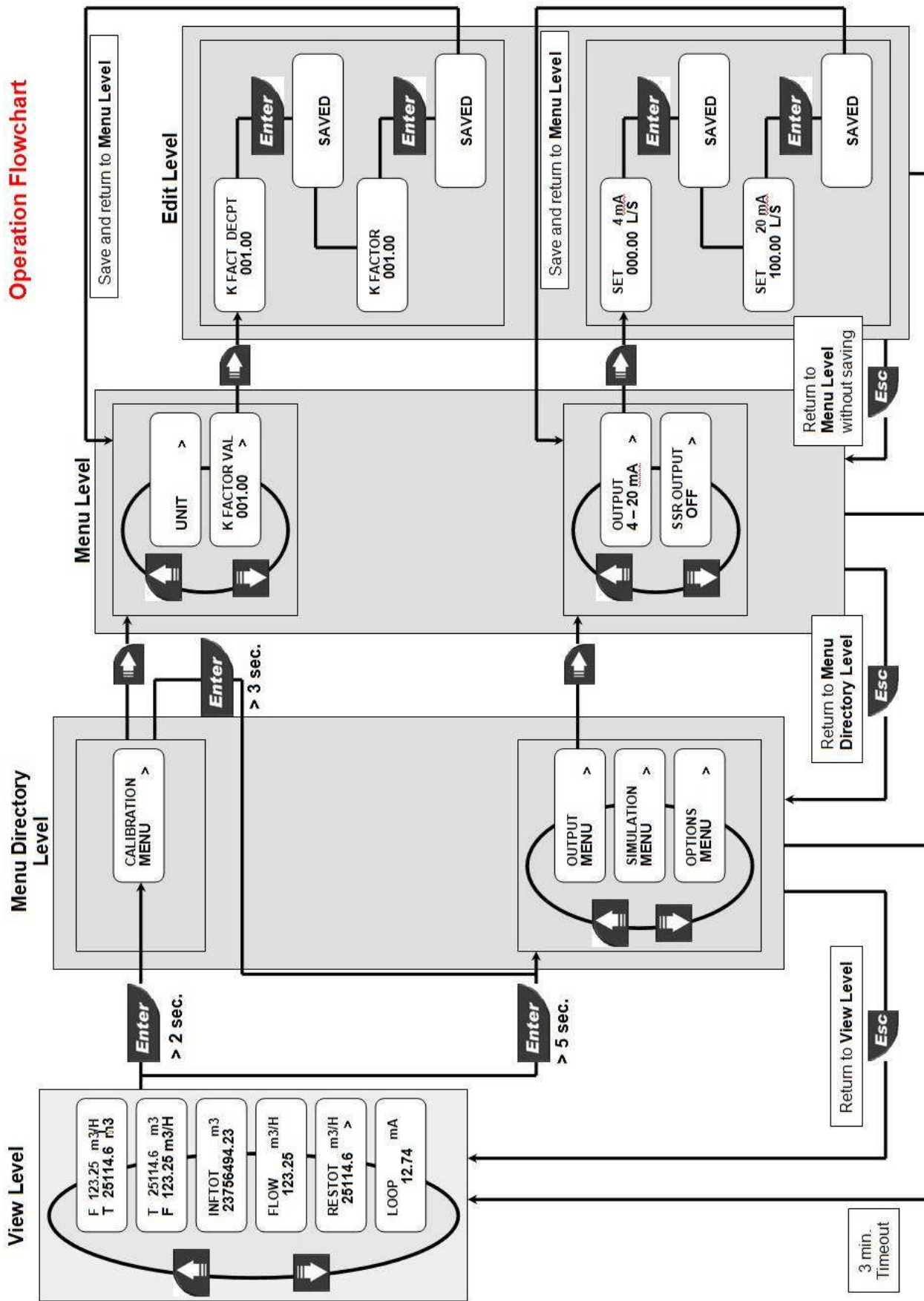

6. View Level

- During normal operation, the flow monitor and transmitter is in View Level displaying all measured values and the status of the analog output and SSR output.
- If the flow monitor is in a different level and no activity occurs for more than 3 minutes, it will return to View Level.
- To select the item you want displayed, press UP or DOWN arrows.
- **Changing display indication does not affect or interrupt instrument operation and calculation.**

Description

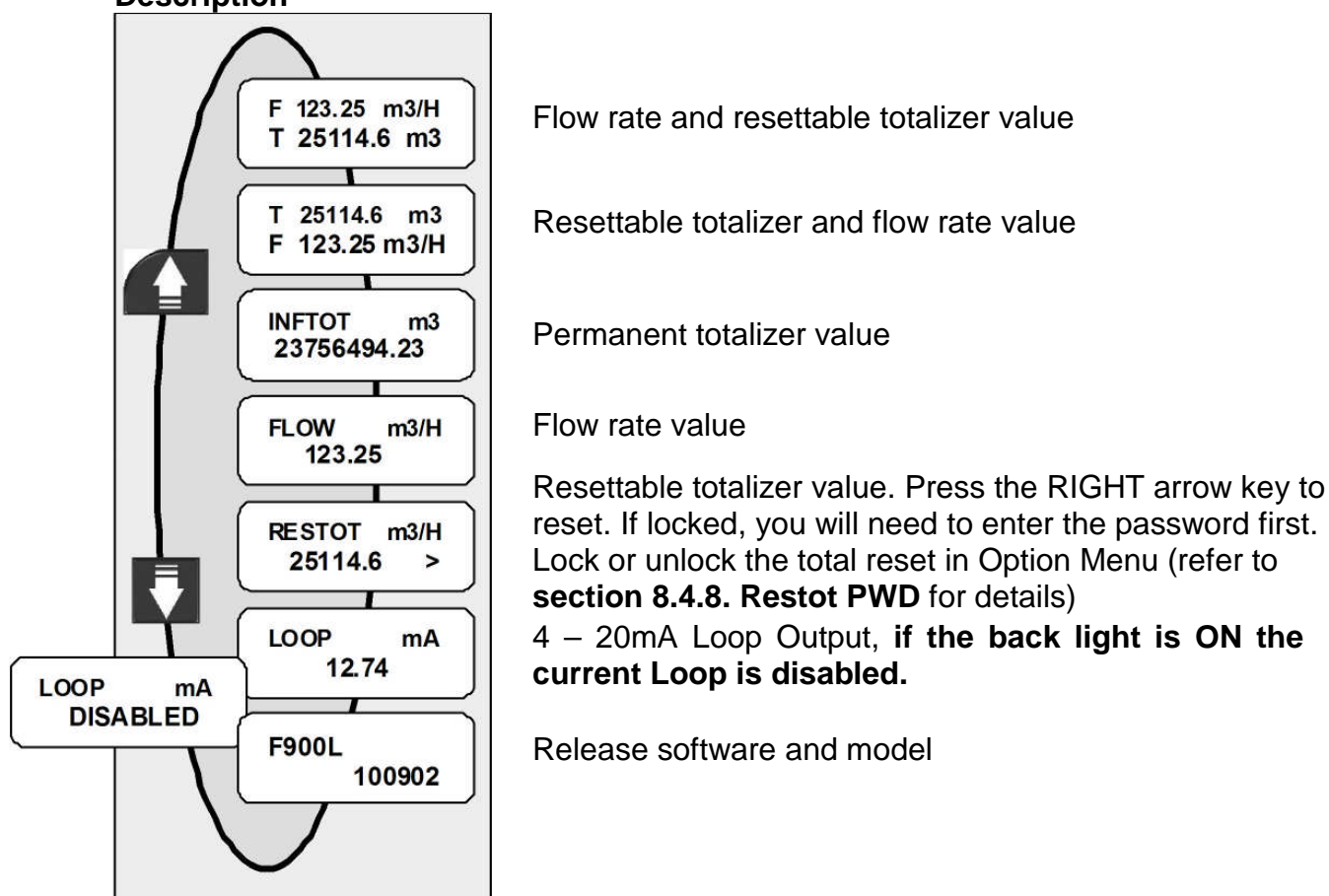

7. Menu Directory Level

Access to this level can be free or password protected. Entering the correct password allows direct access to next levels and to all editable items in all menus, until a return to View Level (refer to **section 8.4.7. Menu PWD** to select password protected access).

Four different menus are available to fully set-up the F9.00.L flow monitor and transmitter. These menus are separated in two different Menu Directories.

In terms of getting started and making measurements, Calibration Menu is the most important menu in the F9.00.L and it is the only one included in the first Menu Directory. Output Menu, Simulation Menu and Option Menu are included together in the second Menu Directory.

7.1. Free access (no password required)

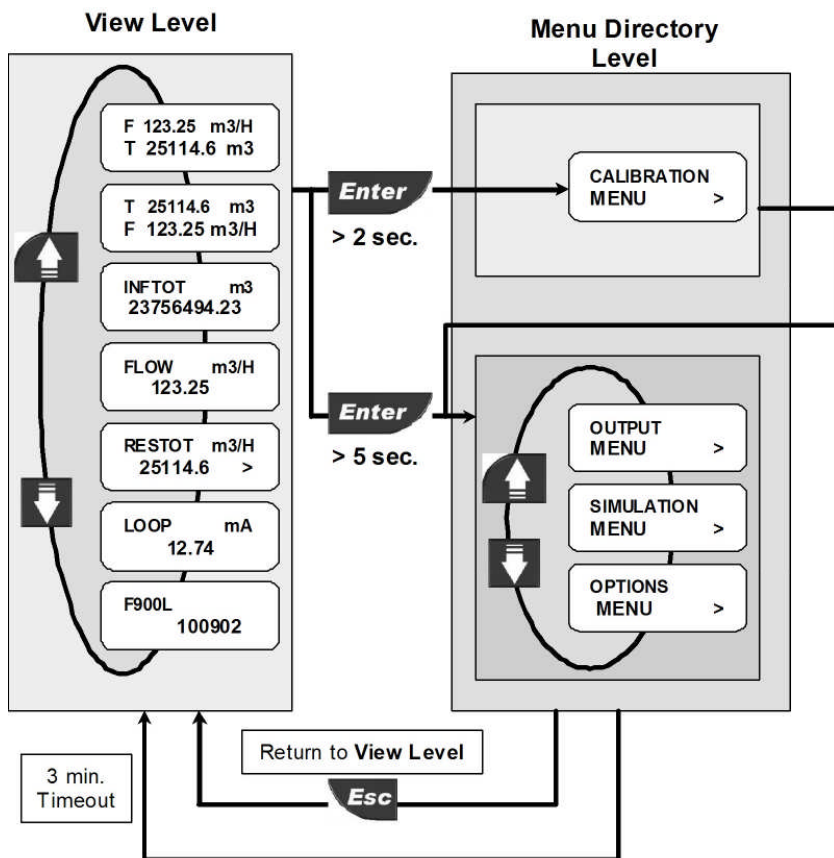

7.2. Password protected access

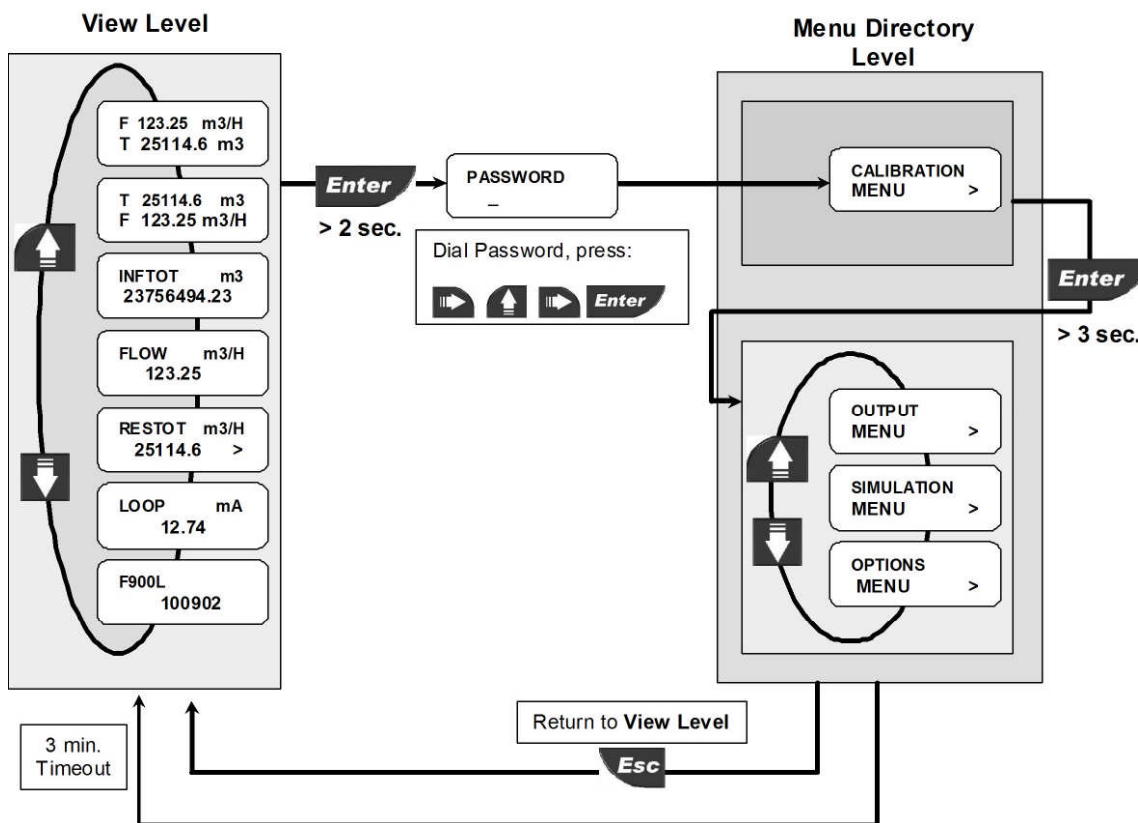

8. Menu and Edit Levels

8.1. Calibration Menu

The F9.00.L basic settings are made in this menu:

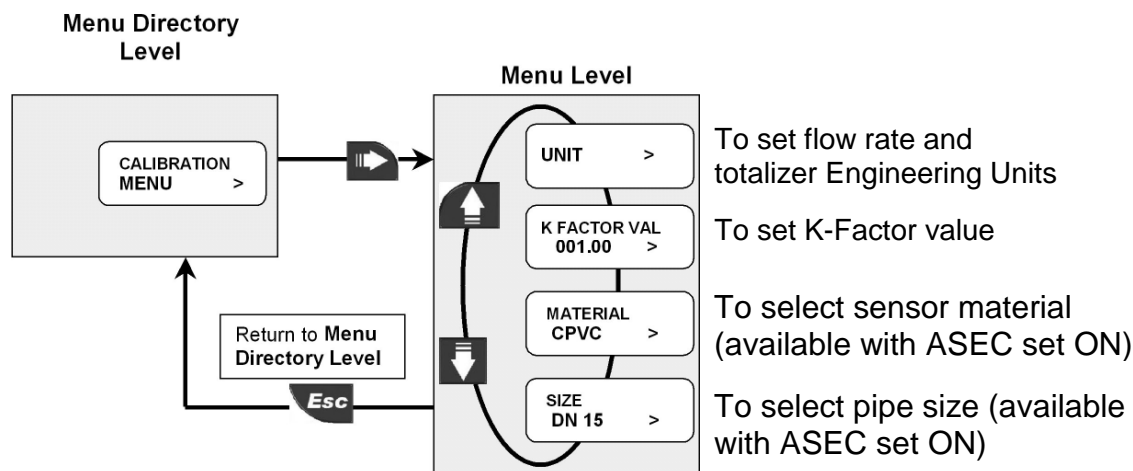

8.1.1. Unit

Set the engineering units for the instant flow rate and the total flow rate. All the options available are displayed on the LCD.

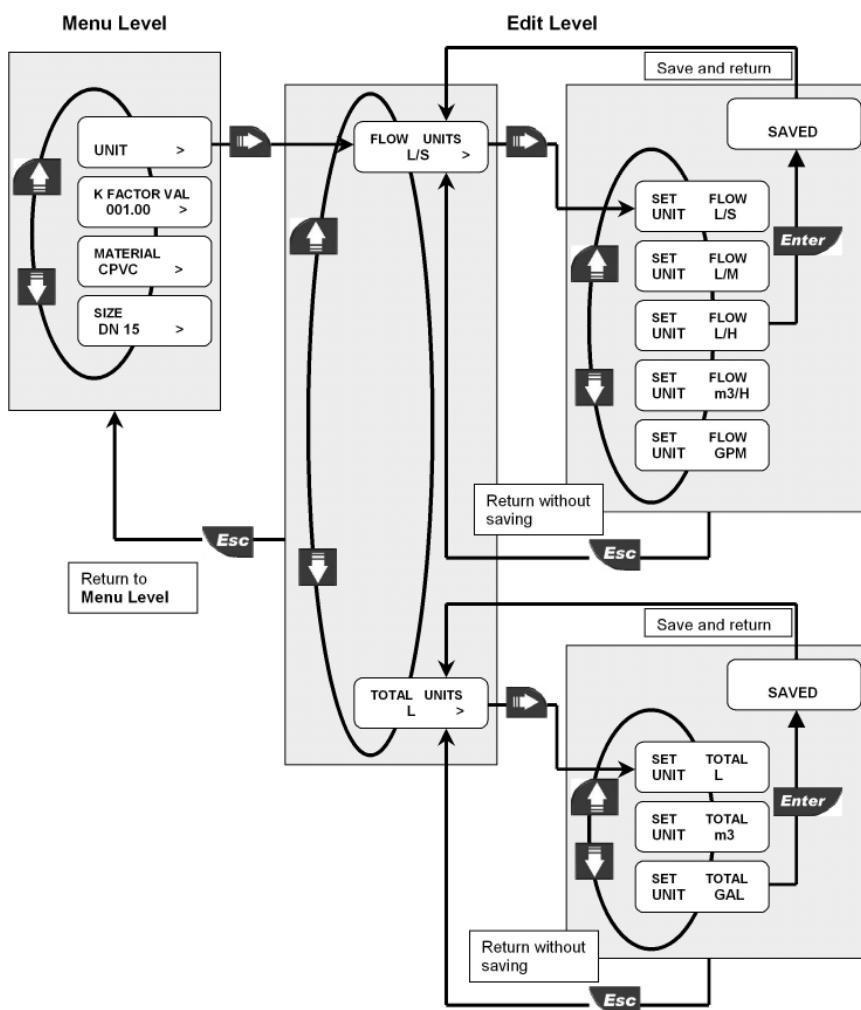

The instrument will automatically convert the values of the two totalizers in the new engineering units.

8.1.2. K-Factor

Set the K-Factor to tell the monitor and transmitter how to convert the input frequency from the flow sensor into a flow rate. The K-factor is unique to the sensor model and to the pipe size and material.

Refer to Flow Sensor Instruction Manual for the correct value.

Limits: 000.01 to 99999 (the K-Factor cannot be set to 0)

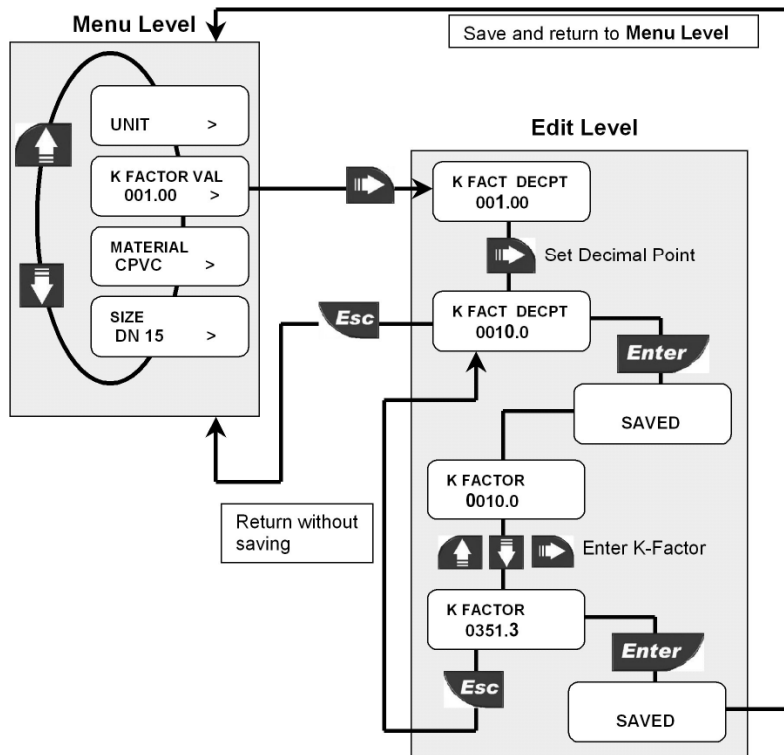

8.1.3. Material

To select sensor's material allows ASEC to improve instrument's performance. You can choose between: CPVC, PVDF or METAL (for Brass and Stainless Steel). "CAUTION": To set OFF ASEC make Material Option unavailable.

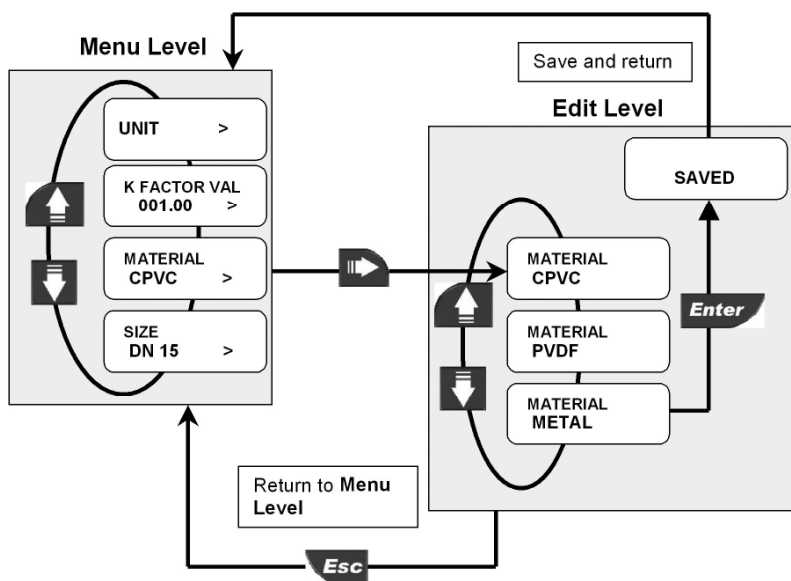

8.1.4 Size

To select pipe's size allows ASEC to improve instrument's performance. You can choose between standard sizes from DN15 to DN300. For pipes bigger than DN300 choose DN300.

“CAUTION”: To set OFF ASEC make size Option unavailable.

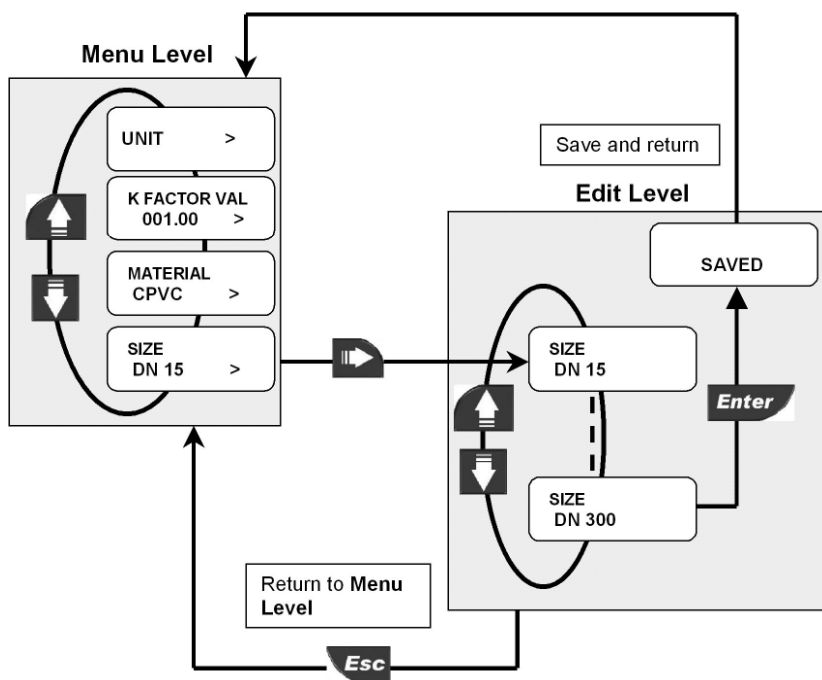

8.2. Output Menu

The F9.00.L analog and digital output are set-up in this menu:

Menu Directory Level

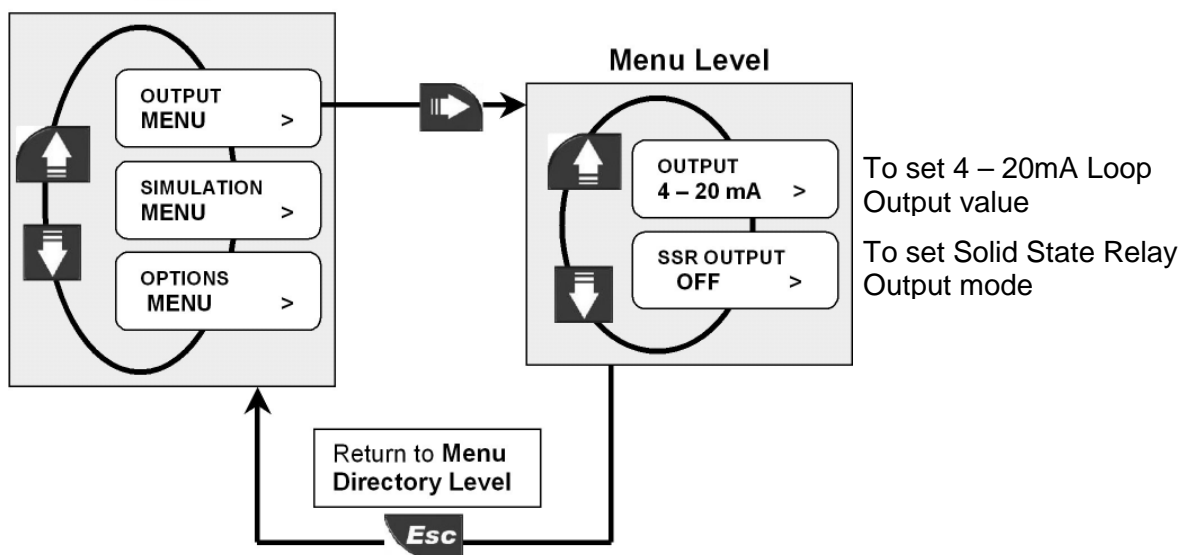

8.2.1. 4 - 20mA Output

The measuring range of the flow, corresponding to the 4-20mA output current is entered here by selecting the minimum and maximum values for the current loop. The

F9.00.L will allow any value from 0.0000 to 99999 and the beginning of the measuring range can be larger than the end of it (inverted output signal). **if the back light is ON it is not possible to set the current loop.**

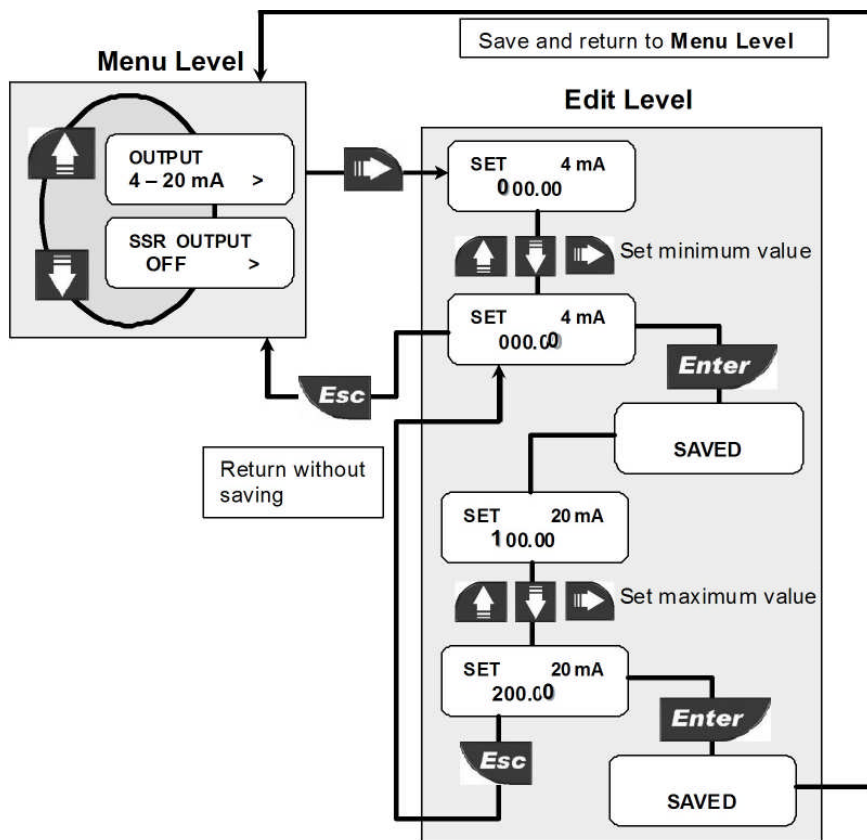

8.2.2. SSR Output (OPT)

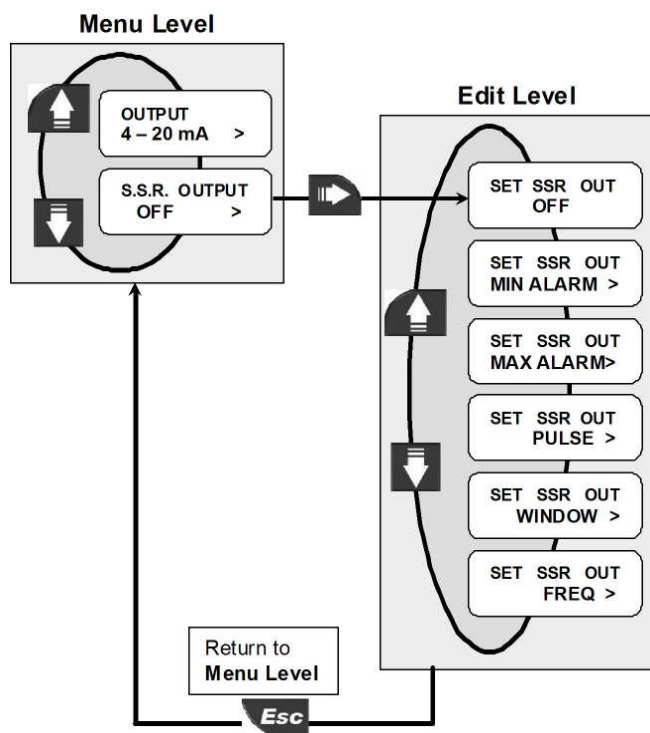

The mode of operation for the Solid State Relay Output (OPT) can be selected between different options: MIN alarm, MAX alarm, volumetric Pulse or Frequency.

The signal can be disabled (set to OFF) if not used.

If the SSR Output is programmed the OPT icon will appear on the third line of the display.

8.2.2.1. SSR Output (OPT): MIN mode

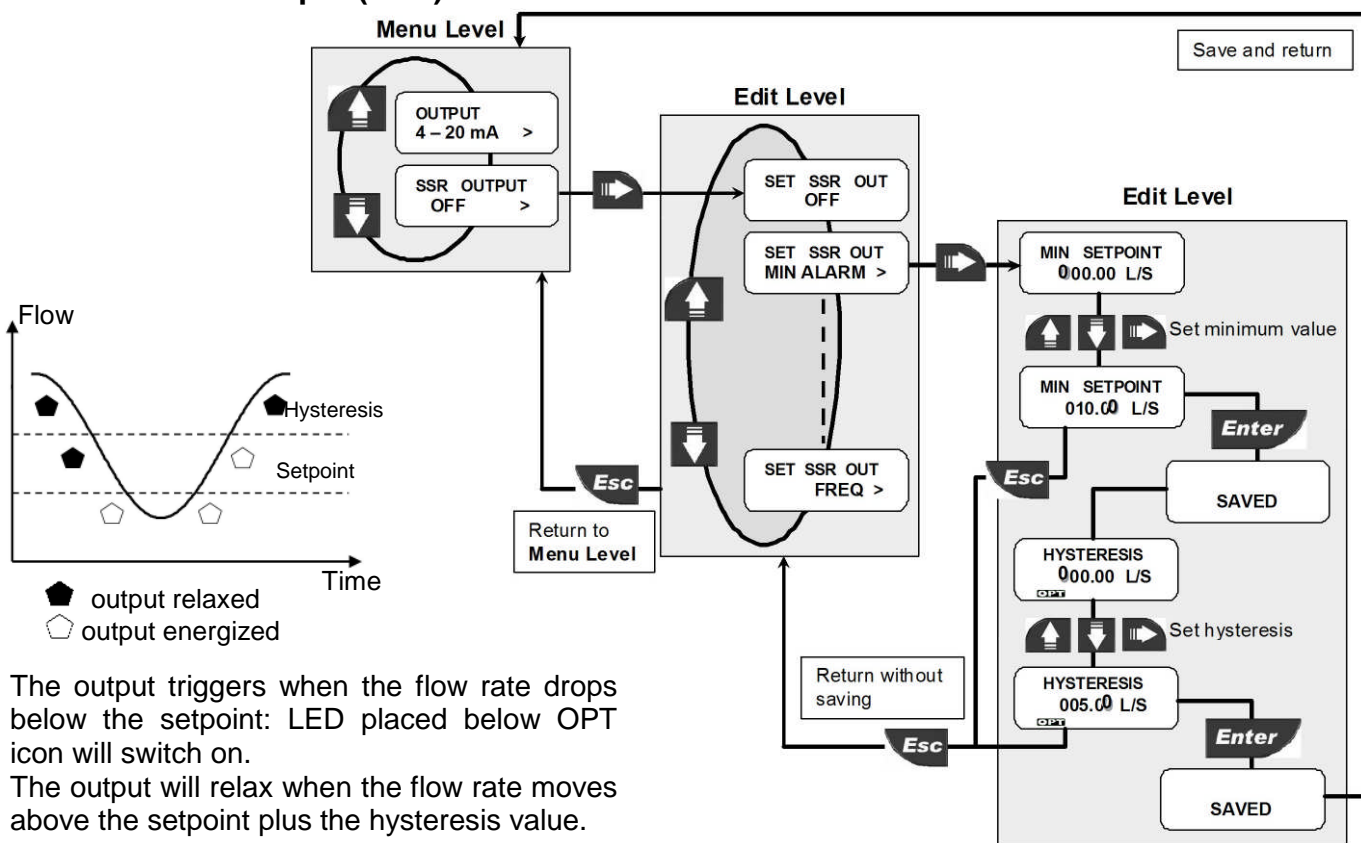

The output triggers when the flow rate drops below the setpoint: LED placed below OPT icon will switch on.
 The output will relax when the flow rate moves above the setpoint plus the hysteresis value.

8.2.2.2. SSR Output (OPT): MAX mode

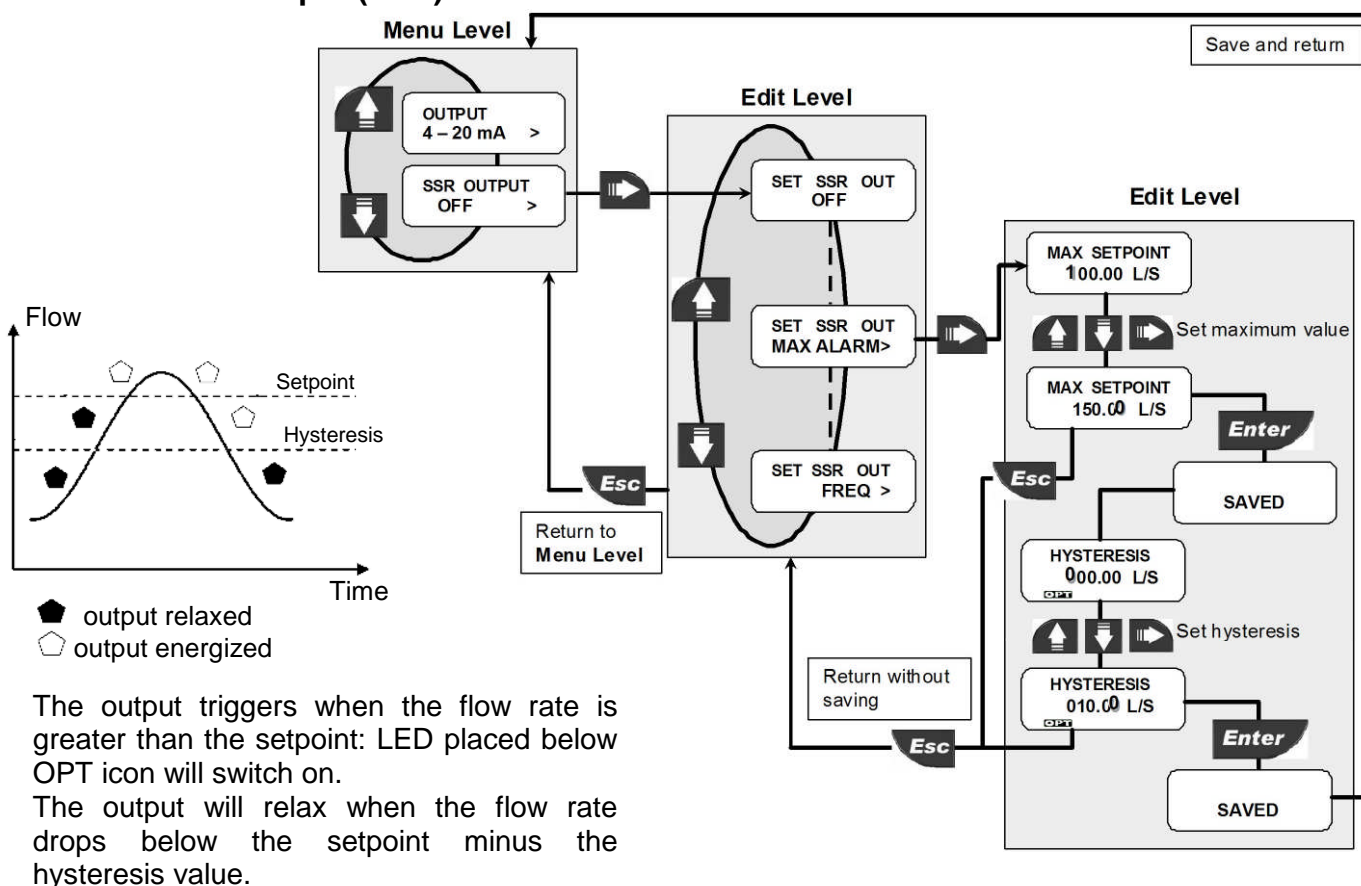

The output triggers when the flow rate is greater than the setpoint: LED placed below OPT icon will switch on.
 The output will relax when the flow rate drops below the setpoint minus the hysteresis value.

8.2.2.3. SSR Output (OPT): PULSE mode

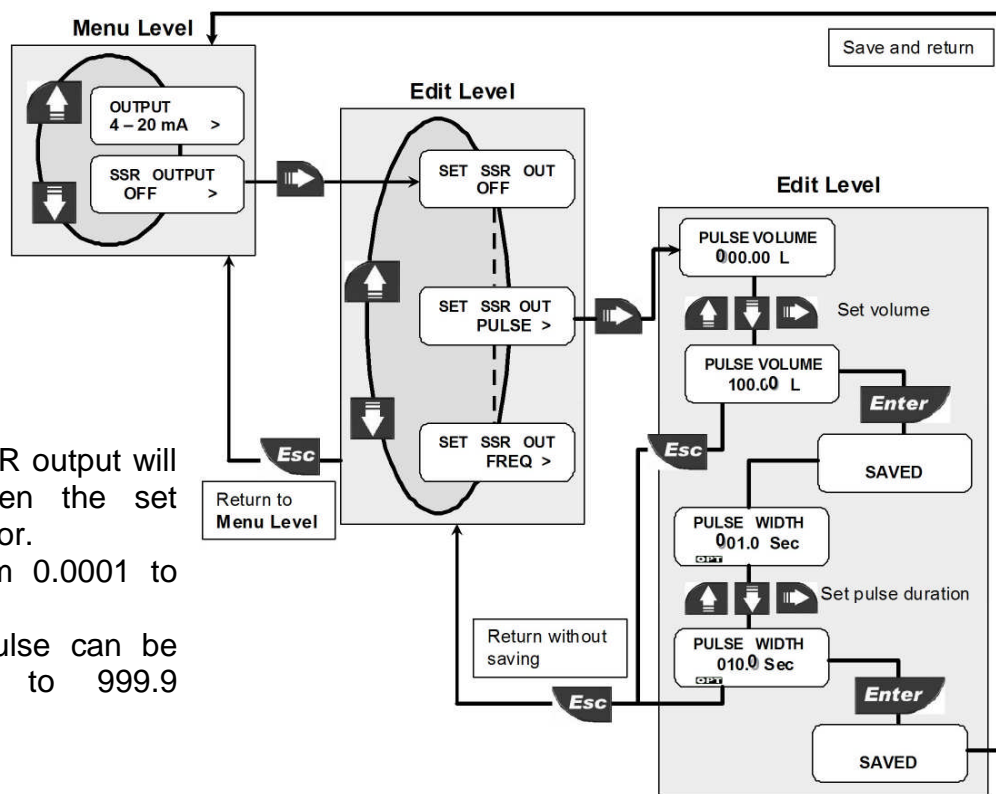

In PULSE mode the SSR output will generate a pulse when the set volume passes the sensor.
 ENTER any value from 0.0001 to 99999.
 The duration of the pulse can be chosen from 000.1 to 999.9 seconds.

8.2.2.4. SSR Output (OPT): Window mode

The output triggers when the flow rate is greater than the max setpoint or when the flow rate drops below the min setpoint: LED placed below OPT icon will switch on. The output will relax when the flow rate is between the two setpoint \pm the hysteresis value.

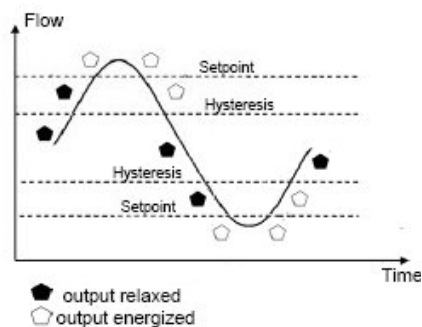
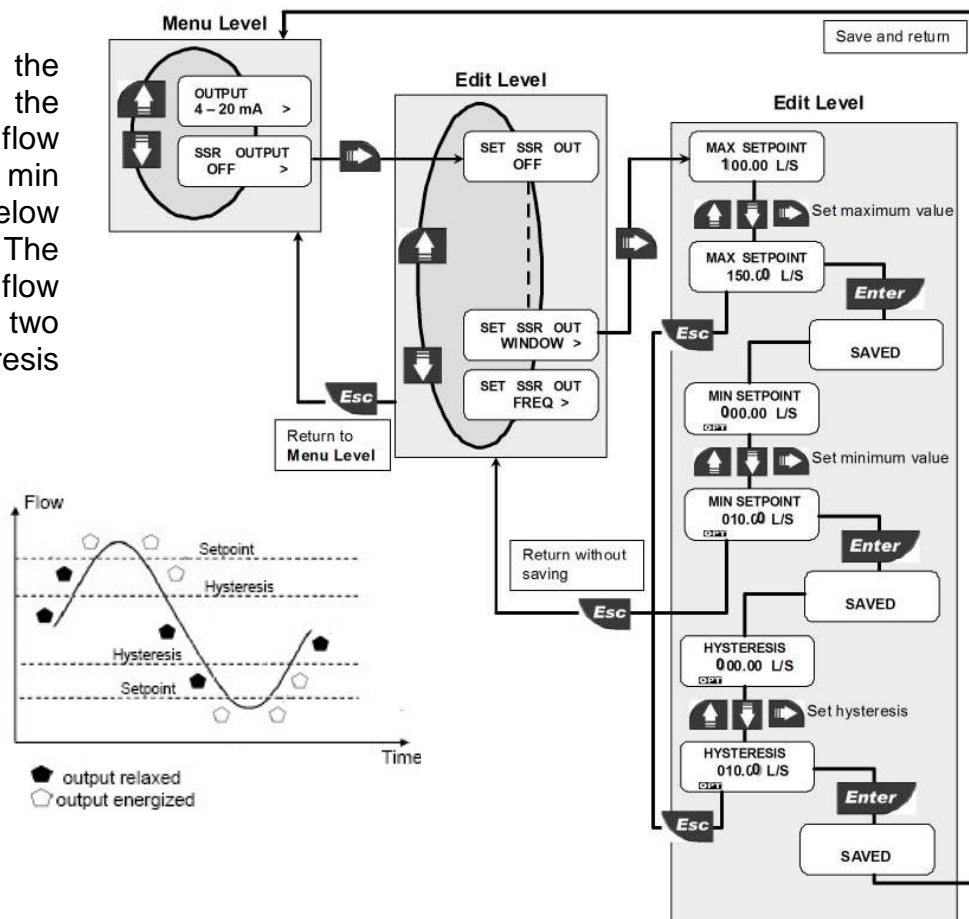

8.2.2.5. SSR Output (OPT): FREQUENCY mode

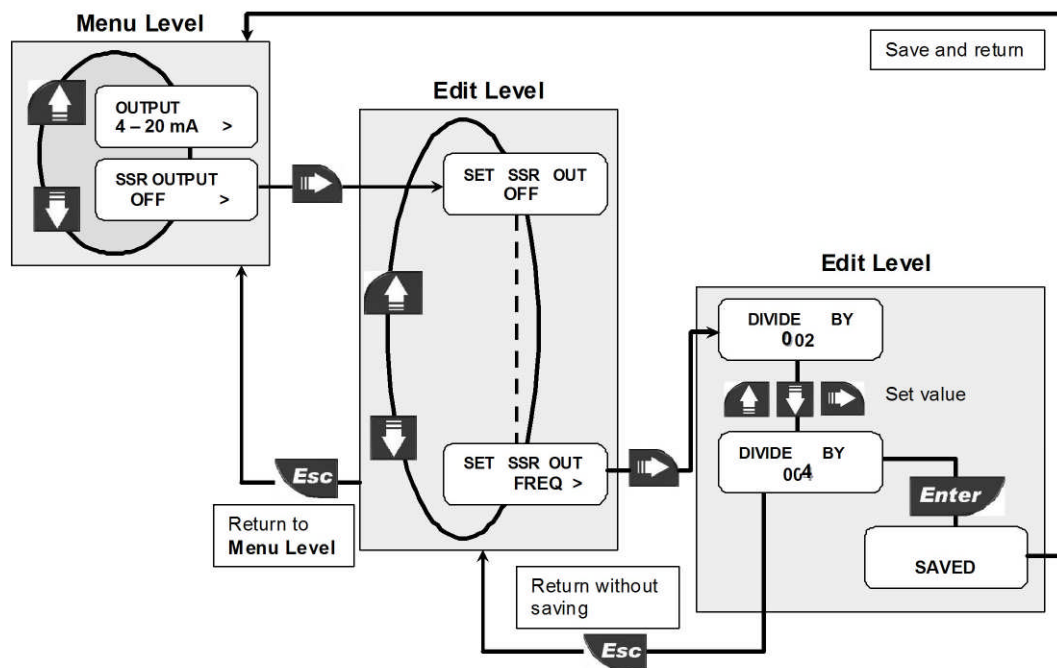

In FREQUENCY mode the SSR output will simulate the sensor frequency divided by the set value. Enter any value between 002 and 255.

8.3. Simulation Menu

The F9.00.L analog and digital output can be simulated and tested in this menu:

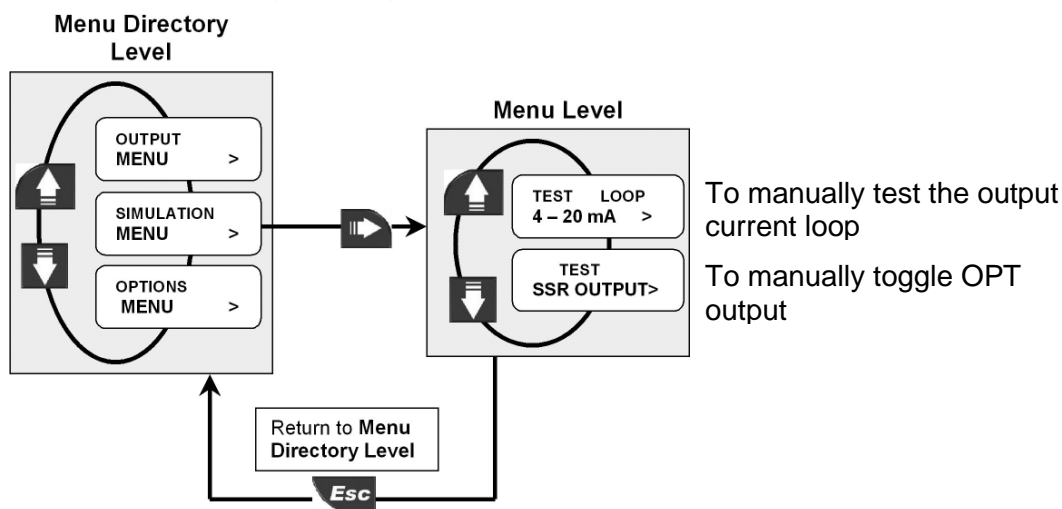

8.3.1. Test 4 – 20mA Loop

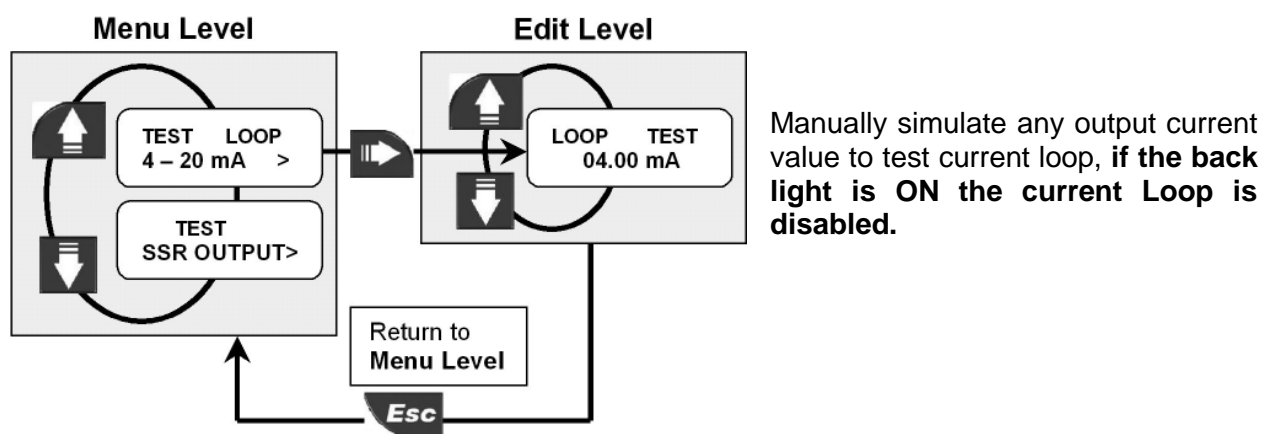

8.3.2. Test SSR Output (OPT)

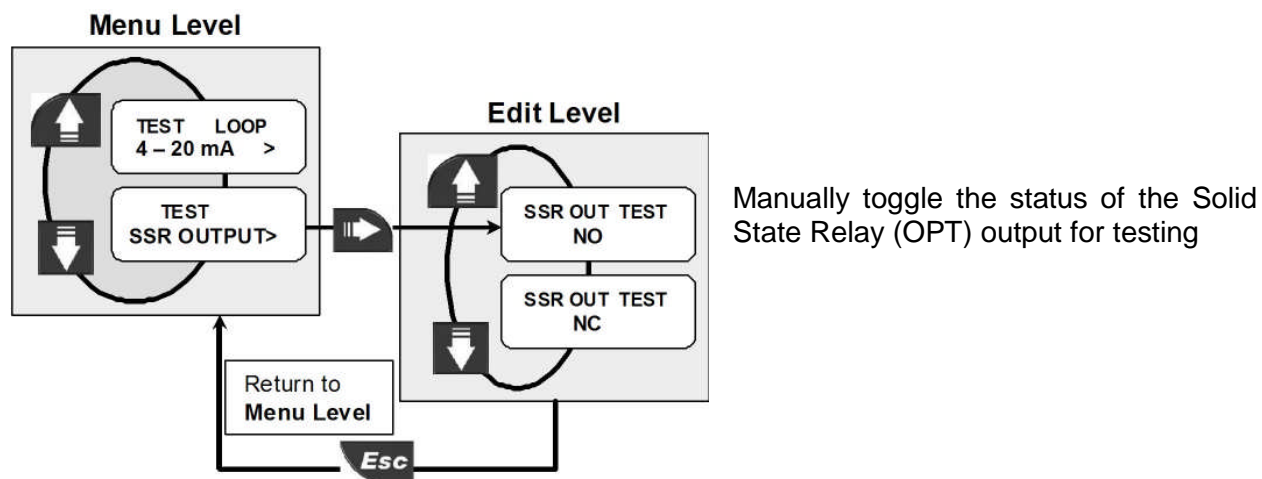

8.4. Options Menu

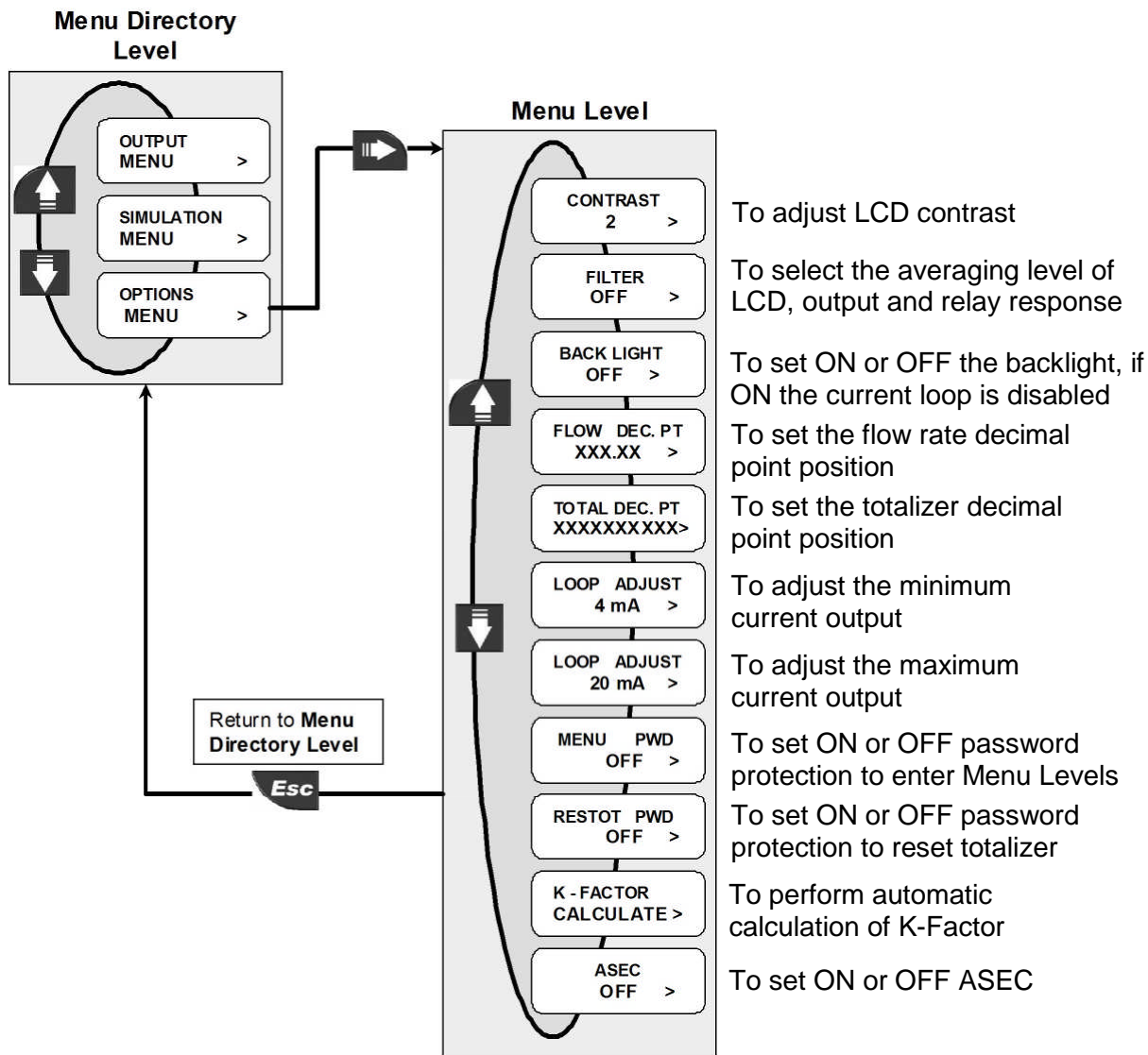

8.4.1. Contrast

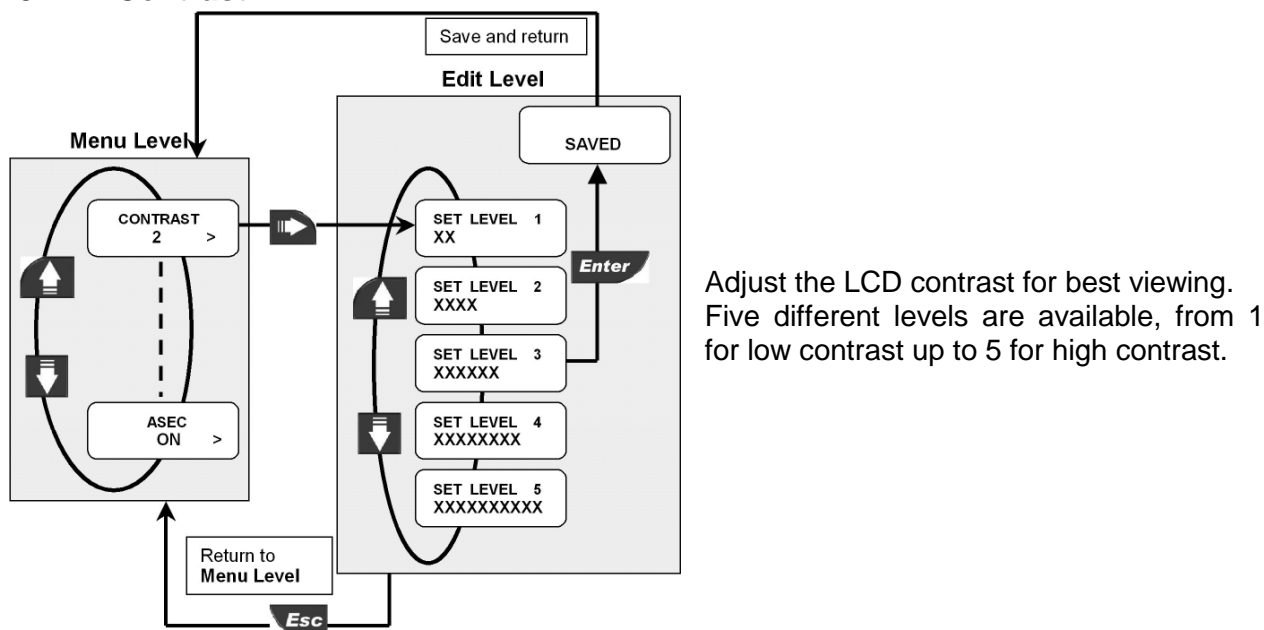

8.4.2. Filter

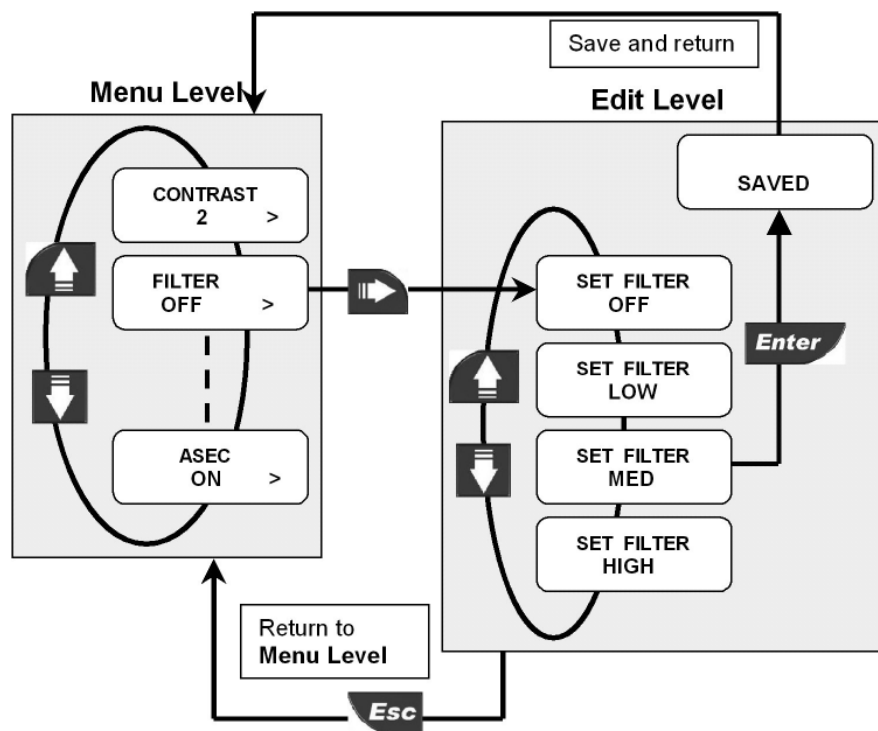

Select the averaging level to dampen LCD indication, output and relay response.
OFF: no dampening effect, near instantaneous response.

8.4.3. Backlight

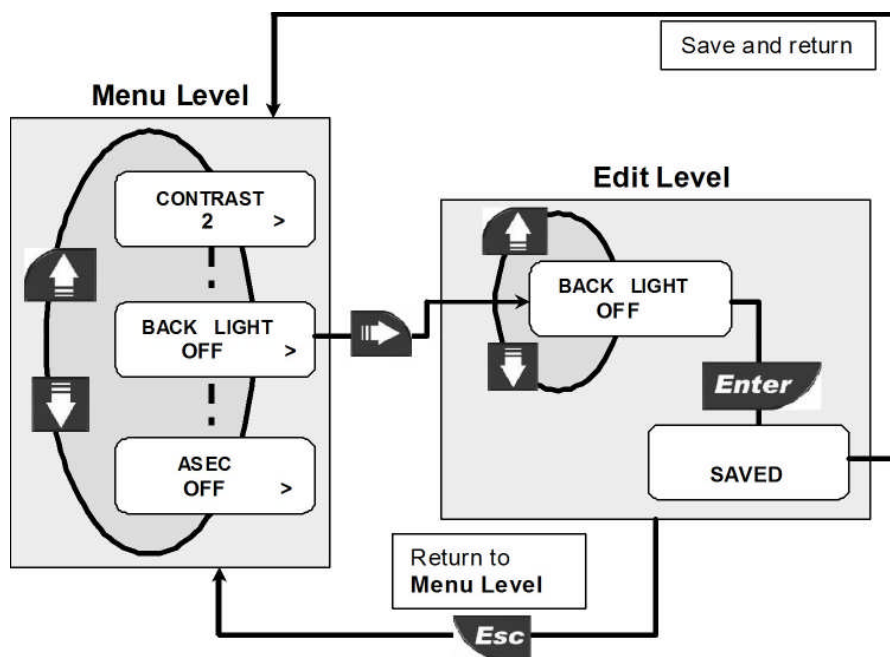

To set ON or OFF the backlight.
If the backlight is ON the current loop is disabled.
Backlight is available with a power supply ≥ 12 Vdc

8.4.4. Flow Decimal Point

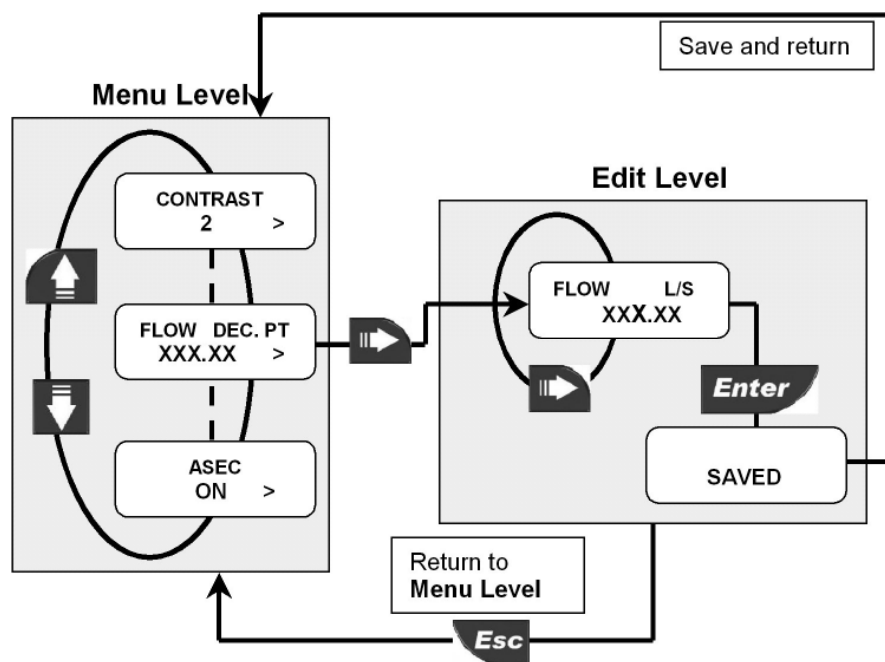

Set the decimal point position to get the best resolution for the application. Select one of the following options:
X.XXXX ; XX.XXX ;
XXX.XX ; XXXX.X ;
XXXXX.

8.4.5. Total Decimal Point

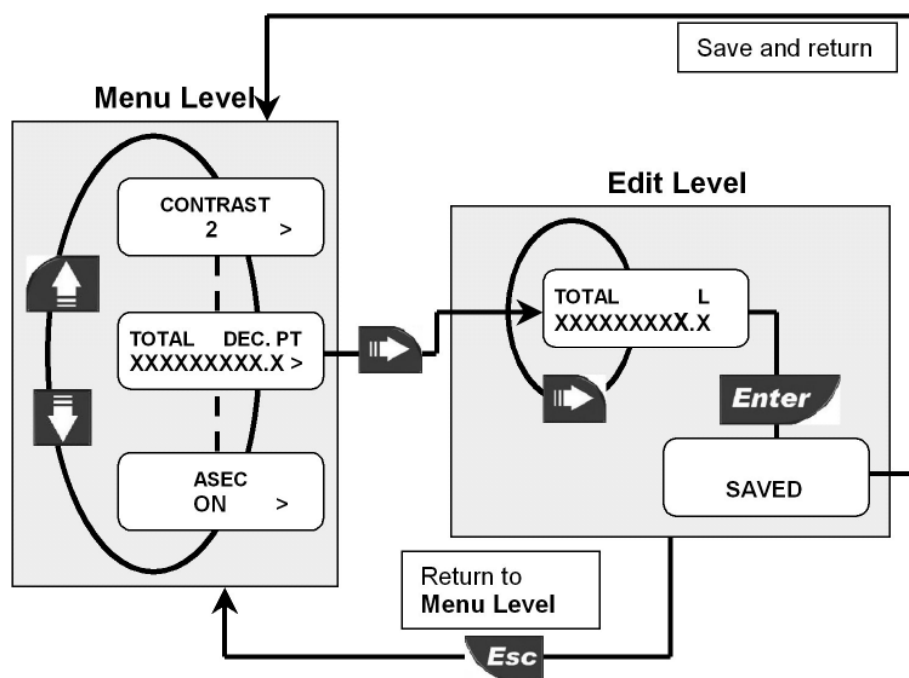

Set the decimal point position to get the best resolution for the application. Select one of the following options
XXXXXXXXXX.XX
XXXXXXXXXX.X
XXXXXXXXXX.

8.4.6. Loop Adjust 4mA

This option can be used to modify the basic 4mA setting to match the transmitter output to any external device. **if the back light is ON the current Loop is disabled.**

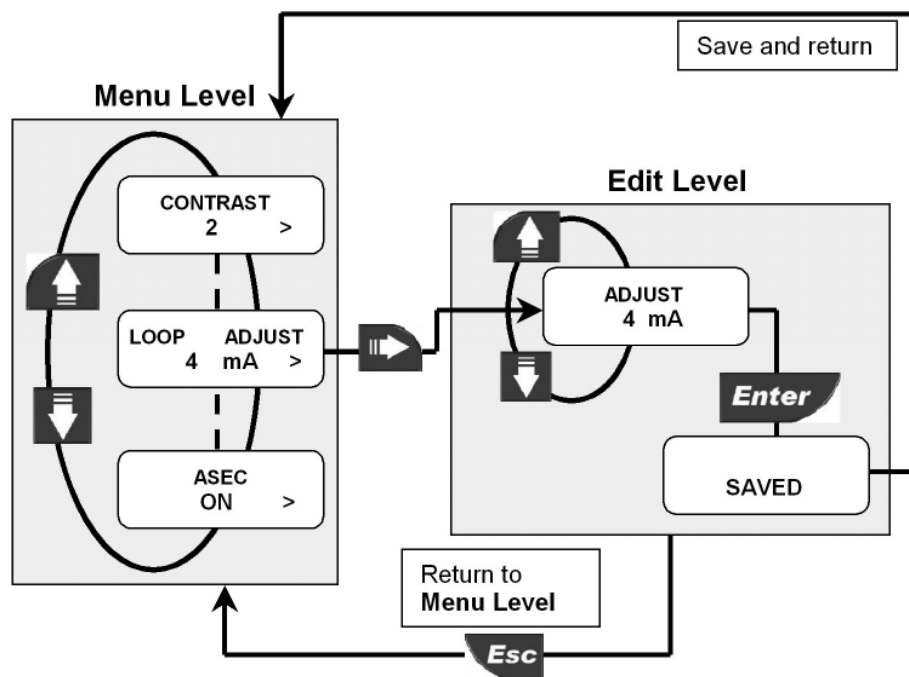

Increment output current value by pressing UP arrow key or decrement it by pressing DOWN arrow key.

8.4.7. Loop Adjust 20mA

This option can be used to modify the basic 20mA setting to match the transmitter output to any external device. **if the back light is ON the current Loop is disabled.**

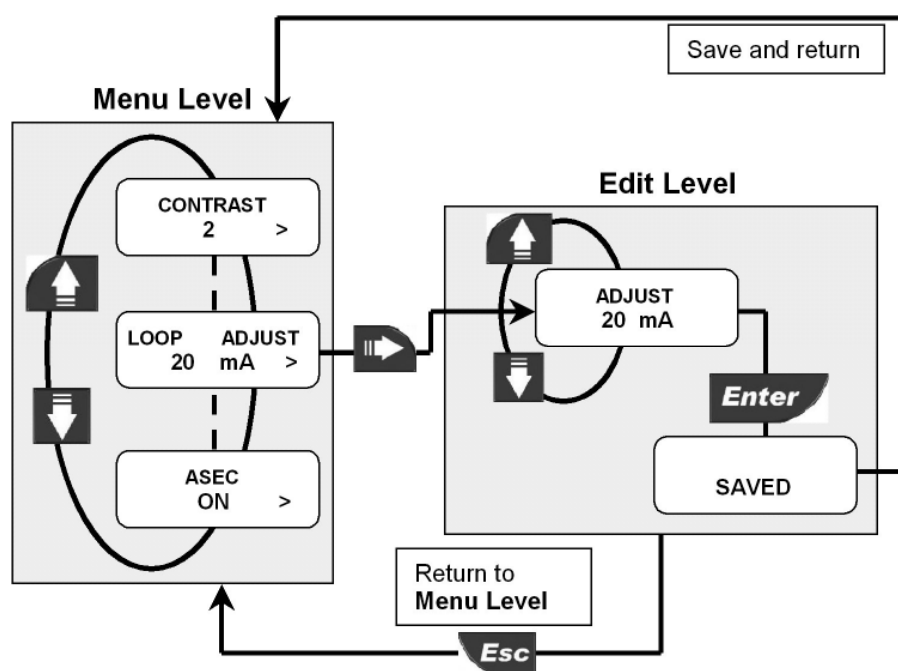

Increment output current value by pressing UP arrow key or decrement it by pressing DOWN arrow key.

8.4.8. Menu PWD

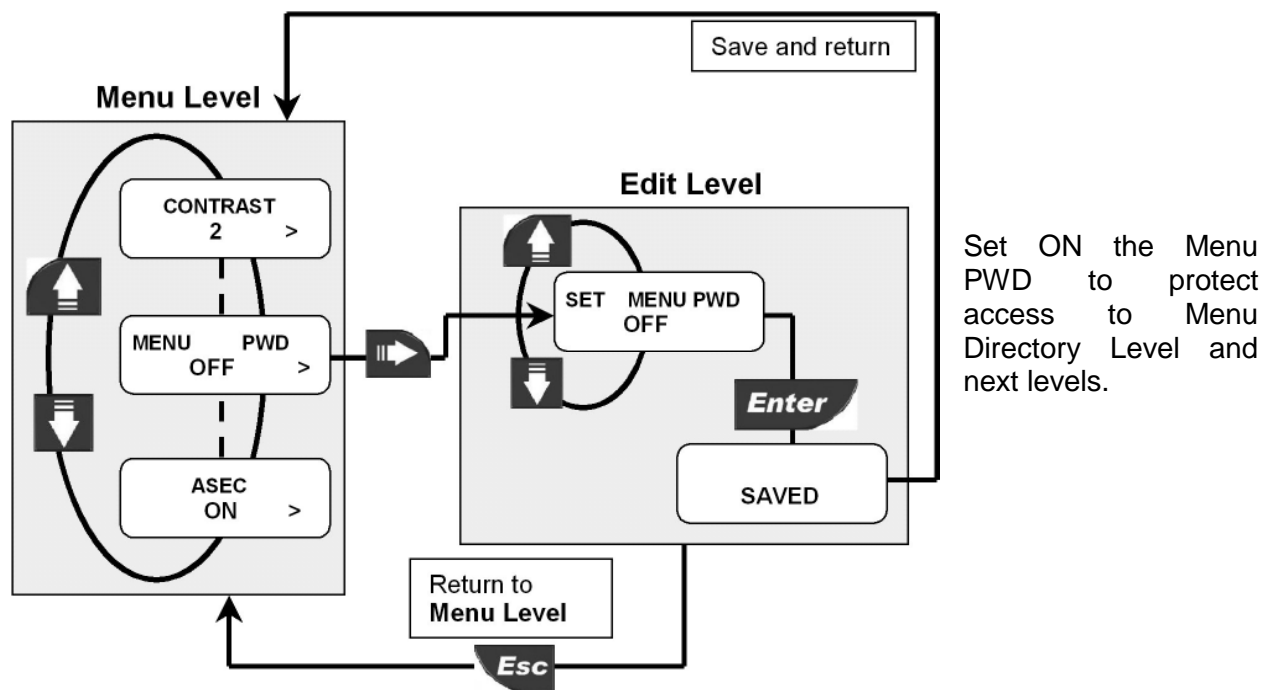

NOTE: the standard password is and it cannot be modified.

8.4.9. Restot PWD

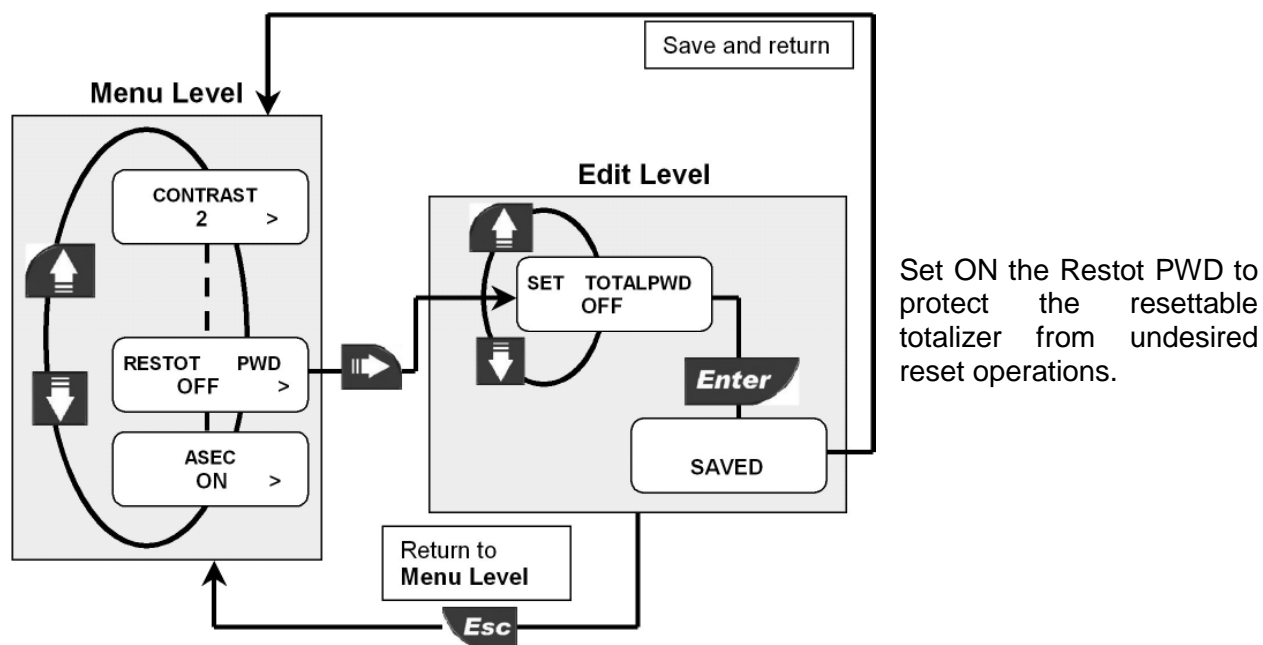

NOTE: the standard password is and it cannot be modified.

8.4.10. K-Factor Calculate

Option used to perform automatic calculation of K-Factor by measuring the volume filled into a tank. This to get the highest accuracy possible.

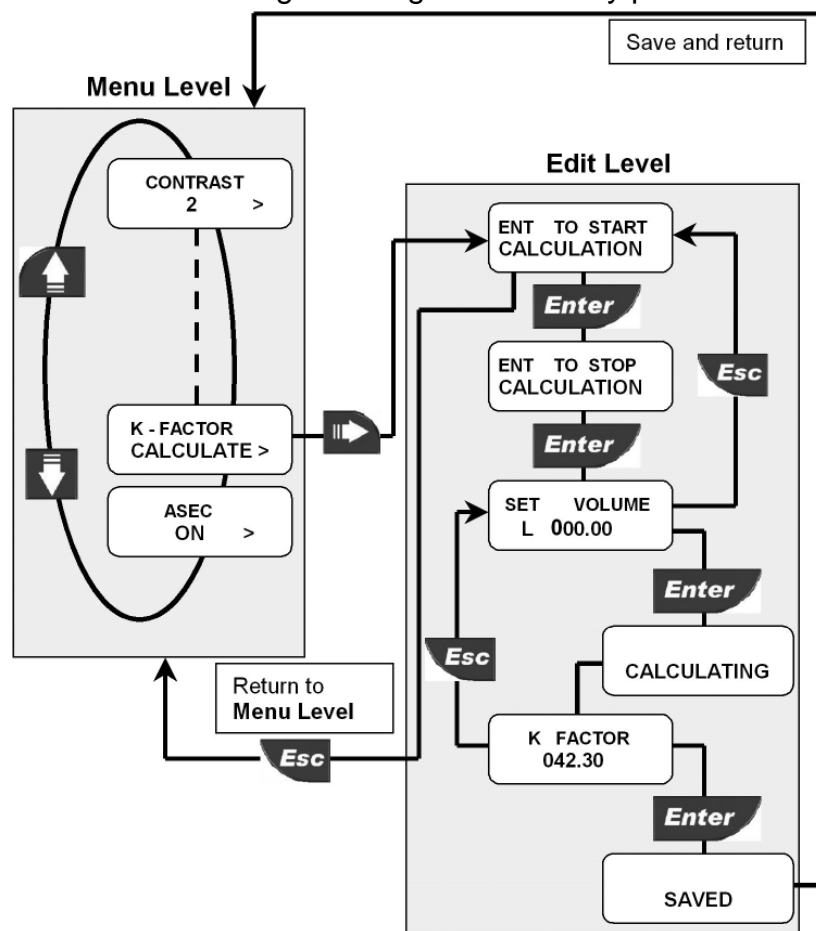

Press ENTER to start calculation. Switch on a pump or open a valve. F9.00.L starts counting pulses from the sensor.

When the tank is full, switch off the pump or close the valve. Press ENTER to stop calculation. F9.00.L stops counting pulses from the sensor.

Enter the volume (in liter) of fluid filled into the tank.

F9.00.L is calculating the new K-Factor.

Successful K-Factor calculation. Press ENTER to accept new K-Factor or ESC to return without saving.

8.4.11. ASEC

ASEC (Automatic Systematic Error Compensation) improve instrument performance. ASEC works starting from application's parameter, particularly sensor body's material and pipe's size. To set ASEC OFF makes Size and Material Options useless, so it

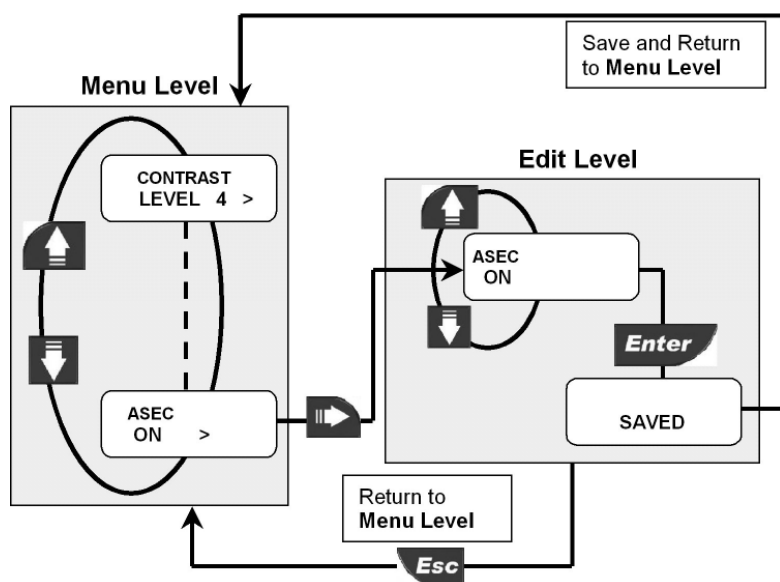





makes them unavailable from Calibration Menu. CAUTION: ASEC is designed to work in conjunction with F 3.00 sensor, so you are advised to set it off if you use another kind of sensor.

9. Troubleshooting

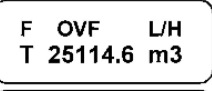
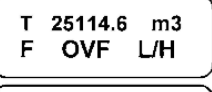
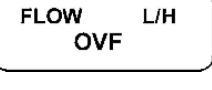
The instrument correctly installed is maintenance-free. The case and the front panel can be cleaned with soft cloth and an appropriate cleaning agent.

9.1. Display messages

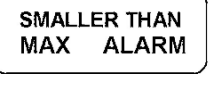
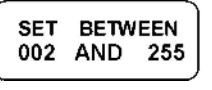
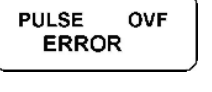
Display	Causes	Solutions
	<ul style="list-style-type: none"> The display is OFF: no power supply provided 	<ul style="list-style-type: none"> Check power supply connection. Check “bridges” between terminals.
  	<ul style="list-style-type: none"> Flow rate is in OVERFLOW: it exceeds the maximum display capability 	<ul style="list-style-type: none"> Change the flow rate engineering units
	<ul style="list-style-type: none"> Input frequency is too large 	<ul style="list-style-type: none"> Check sensor connection If not FlowX3 sensor, verify sensor data sheet and compatibility
	<ul style="list-style-type: none"> K-Factor cannot be set to 0 Volume corresponding to one pulse (when setting OPT as Pulse Out) cannot be set to 0 Volume filled into the tank (during K-factor calculation procedure) cannot be set to 0 	<ul style="list-style-type: none"> Enter K-Factor value from 000.01 to 99999 Enter any volume from 0.0001 to 99999 Enter any volume from 000.01 to 999.99
	<ul style="list-style-type: none"> With the new engineering unit chosen, the totalized volume exceeds maximum display capability 	<ul style="list-style-type: none"> Change the totalizer engineering units
	<ul style="list-style-type: none"> Hysteresis value is larger than the MAX alarm value: the instrument will never get out of the maximum alarm Window mode : the min alarm value has to be smaller than max alarm value 	<ul style="list-style-type: none"> Change the hysteresis value Set the max min alarm value smaller than max alarm value
	<ul style="list-style-type: none"> The dividing value (when setting OPT as Freq Out) is out of range 	<ul style="list-style-type: none"> Enter any value between 002 and 255
	<ul style="list-style-type: none"> The pulse width is too wide compared to pulse frequency 	<ul style="list-style-type: none"> Increase volume setting Decrease pulse width Reduce flow rate

Display	Causes	Solutions
BIGGER THAN MIN ALARM	<ul style="list-style-type: none"> In window mode : max alarm smaller than min alarm 	<ul style="list-style-type: none"> Enter max value bigger than min alarm
SET VALUE ERROR	<ul style="list-style-type: none"> The value is bigger than the difference between the max value and min value in window mode 	<ul style="list-style-type: none"> Change the hysteresis value
K FACTOR OUT OF RANGE	<ul style="list-style-type: none"> The value calculated during the K-Factor calculation procedure is out of range 	<ul style="list-style-type: none"> Move decimal point position Check entered volume
DISABLED 4 – 20 mA	<ul style="list-style-type: none"> The backlight is ON 	<ul style="list-style-type: none"> To set the backlight OFF
OUT OF RANGE 0.3–999.9 SEC	<ul style="list-style-type: none"> Pulse width (when setting OPT as Pulse Out) is out of range. 	<ul style="list-style-type: none"> Enter any value between 0.3 and 999.9

10. Ordering Data

FlowX3 F9.00.L

Part No.	Description	Wire Power Tech.	Power Supply	Input	Output
F9.00.L	Flow Monitor & Transmitter	2 wire	12 to 24 VDC	1 (Freq.)	1 (4...20mA) 1 (Solid State Relay)

FlowX3 F9.00.P1.L (Panel Mount version)

Part No.	Description	Wire Power Tech.	Power Supply	Input	Output
F9.00.P1.L	Panel Mount Flow Monitor & Transmitter	2 wire	12 to 24 VDC	1 (Freq.)	1 (4...20mA) 1 (Solid State Relay)

FlowX3 F9.00.WX.L (Wall Mount version)

Part No.	Description	Wire Power Tech.	Power Supply	Input	Output
F9.00.W1.L	Wall Mount Flow Monitor & Transmitter	2 wire	12 to 24 VDC	1 (Freq.)	1 (4...20mA) 1 (Solid State Relay)
F9.00.W2.L	Wall Mount Flow Monitor & Transmitter	2 wire	110 to 230 VAC	1 (Freq.)	1 (4...20mA) 1 (Solid State Relay)

**FlowX3 F9.00.XX.L
(Compact Field Mount version)**

Part No.	Description	Wire Power Tech.	Power Supply	Input	Output	Sensor Length	Sensor Body	Sensor O-rings
F9.00.01.L	Field Mount Flow Monitor & Transmitter	2 wire	12 to 24 VDC	1 (Freq.)	1 (4...20mA) 1 (Solid State Relay)	L0	CPVC	EPDM
F9.00.02.L	Field Mount Flow Monitor & Transmitter	2 wire	12 to 24 VDC	1 (Freq.)	1 (4...20mA) 1 (Solid State Relay)	L0	CPVC	FPM
F9.00.03.L	Field Mount Flow Monitor & Transmitter	2 wire	12 to 24 VDC	1 (Freq.)	1 (4...20mA) 1 (Solid State Relay)	L1	CPVC	EPDM
F9.00.04.L	Field Mount Flow Monitor & Transmitter	2 wire	12 to 24 VDC	1 (Freq.)	1 (4...20mA) 1 (Solid State Relay)	L1	CPVC	FPM
F9.00.05.L	Field Mount Flow Monitor & Transmitter	2 wire	12 to 24 VDC	1 (Freq.)	1 (4...20mA) 1 (Solid State Relay)	L0	PVDF	EPDM
F9.00.06.L	Field Mount Flow Monitor & Transmitter	2 wire	12 to 24 VDC	1 (Freq.)	1 (4...20mA) 1 (Solid State Relay)	L0	PVDF	FPM
F9.00.07.L	Field Mount Flow Monitor & Transmitter	2 wire	12 to 24 VDC	1 (Freq.)	1 (4...20mA) 1 (Solid State Relay)	L1	PVDF	EPDM
F9.00.08.L	Field Mount Flow Monitor & Transmitter	2 wire	12 to 24 VDC	1 (Freq.)	1 (4...20mA) 1 (Solid State Relay)	L1	PVDF	FPM
F9.00.09.L	Field Mount Flow Monitor & Transmitter	2 wire	12 to 24 VDC	1 (Freq.)	1 (4...20mA) 1 (Solid State Relay)	L0	316SS	EPDM
F9.00.10.L	Field Mount Flow Monitor & Transmitter	2 wire	12 to 24 VDC	1 (Freq.)	1 (4...20mA) 1 (Solid State Relay)	L0	316SS	FPM
F9.00.11.L	Field Mount Flow Monitor & Transmitter	2 wire	12 to 24 VDC	1 (Freq.)	1 (4...20mA) 1 (Solid State Relay)	L1	316SS	EPDM
F9.00.12.L	Field Mount Flow Monitor & Transmitter	2 wire	12 to 24 VDC	1 (Freq.)	1 (4...20mA) 1 (Solid State Relay)	L1	316SS	FPM
F9.00.13.L	Field Mount Flow Monitor & Transmitter	2 wire	12 to 24 VDC	1 (Freq.)	1 (4...20mA) 1 (Solid State Relay)	L0	BRASS	EPDM
F9.00.14.L	Field Mount Flow Monitor & Transmitter	2 wire	12 to 24 VDC	1 (Freq.)	1 (4...20mA) 1 (Solid State Relay)	L0	BRASS	FPM
F9.00.15.L	Field Mount Flow Monitor & Transmitter	2 wire	12 to 24 VDC	1 (Freq.)	1 (4...20mA) 1 (Solid State Relay)	L1	BRASS	EPDM
F9.00.16.L	Field Mount Flow Monitor & Transmitter	2 wire	12 to 24 VDC	1 (Freq.)	1 (4...20mA) 1 (Solid State Relay)	L1	BRASS	FPM

Mounting Kits

Part No.	Name	Description
F9.KC1	Compact mounting Kit	Plastic adapter with gasket, compact cap, locking ring and 4 fixing screws
F9.KP1.2	Panel mounting Kit	Mounting bracket with gasket
F9.KW1	Wall mounting Kit	Plastic adapter with gasket and fixing screws
F9.KW2	Wall mounting Kit with Power Supply	Plastic adapter with gasket, fixing screws and 110/230VAC to 24VDC power supply included

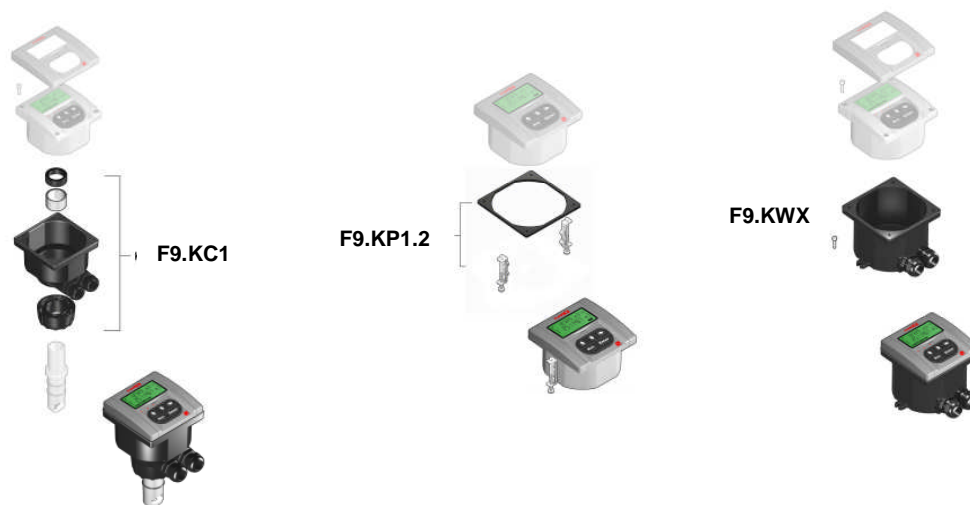

Spare Parts

Item	Part No.	Name	Description
1	F9.SP1	Cover	PC front cover, 1 LED
2	F9.SP4.1	PG 13.5	PG13.5 Cable Gland for Compact or Wall mounting Kit
2	F9.SP4.2	PG 11	PG11 Cable Gland for Compact or Wall mounting Kit

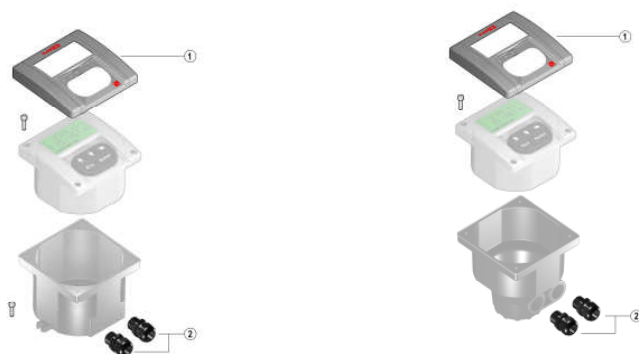

F.I.P. Formatura Iniezione Polimeri S.p.A.
Loc. Pian di Parata, 16015 Casella (GE) – Italy
Tel +39 010 96211 – Fax +39 010 9621209

www.flsnet.it