

F111 Flow Sensor for Hot Tap Installation

INSTRUCTION MANUAL

EN 10-11

Table of Contents

1. Introduction.....	2
Safety Instructions.....	2
Unpacking.....	2
2. Description.....	2
Main Features.....	3
Technical Data.....	3
3. Installation.....	4
Dimensions.....	4
Set the sensor to work.....	4
4. K-Factor Tables.....	10

1. Introduction

**CAUTION**

1.1. Safety Instructions

General Statements

- ❑ The sensor F111.X has only been designed to measure the flow of liquids.
- ❑ Do not install and service the sensor without following the Instruction Manual.
- ❑ This sensor is designed to be connected to other instruments which can be hazardous if used improperly. Read and follow all associated instrument manuals before using with this sensor.
- ❑ Sensor installation and wiring connections should only be performed by qualified staff.
- ❑ Do not modify product construction.

Installation and Commissioning Statements

- ❑ Remove power to the sensor before wiring any connection.
- ❑ Do not exceed maximum temperature/pressure data.
- ❑ To clean the sensor, use only chemical compatible products.

1.2. Unpacking

Please verify the product is complete and without any damage. The package should include:

- A steel tube rod (wall thickness tester) with flow sensor integrated
- A steel joint for screwing the sensor to the saddle
- A protective plastic cylinder
- An instruction manual

2. Description

The new stainless steel sensor FLS 111 is a compact flow sensor equipped with an E-CTFE five bladed rotor with a permanent magnet integrated into each blade and with a ceramic bearing embedded on each side. Combined with the ceramic shaft, the bearings guarantee long life and excellent chemical resistance. The rotational speed is proportional to the flow and as the magnet in each blade passes close to the transducer, an output pulse is generated.

The output pulse is processed to a square wave output frequency linearly proportional to the flow velocity; the signal may be transmitted up to 10 meters.

The electronics are entirely encapsulated in epoxy resin which ensures that the instrument is suitable for corrosive atmospheres.

The sensor can be assembled in pressurised pipes using a proper clamp saddle and it allows, by a simple procedure, to directly measure the internal diameter during the installation, enabling to precisely position the sensor into the pipe and get the max accuracy.

2.2. Main Features

- Adjustable sensor position
- Accurate positioning needless to know previously the pipe's internal diameter
- Stainless steel construction with insertion paddlewheel technology
- E-CTFE rotor with ceramic shaft and bearings
- Wet-tap installation
- Pressure intake
- Suitable for assembling on a wide range of wet-tap clamp saddles with 2" GAS branch
- Compatible with most data logger on the market

2.3. Technical Data

Power supply:	3.6 to 5 VDC (3.6 V lithium batteries as well)
Current consumption:	5 μ A max.
Output signal:	square wave 3.6 to 5 Vpp
Electrical connections:	round cable 3x1.5 mm according CEI 20-22:
Colors:	Blue = +VDC
	Brown = GND
	Yellow/Green = Signal
Cable length:	standard 10 meters (32.8 feet)
Flow velocity range:	0.15 to 10 m/s (0.5 to 33 fps)
Accuracy:	± 0.75 % f.s.
Repeatability:	± 0.5 % f.s.
Pipe size range:	DN 80 to DN 600 (3 to 24 inch) (standard)
Maximum % solids:	10 %, with particles size not exceeding 0.5 mm cross section
Materials:	
sensor body:	stainless steel AISI 304
rotor:	E-CTFE, 5 blades with magnets
rotor shaft:	ceramic (Al_2O_3)
bearings:	ceramic (Al_2O_3)
seals:	EPDM
measuring rod:	stainless steel AISI 304
fixing joint:	stainless steel AISI 304
protection cylinder:	PVC
Pressure intake:	quick connection 3.8"
thread of the fixing joint to the saddle:	GAS 2"
Quality standards:	CE
	ISO 9002

3. Installation

3.1. Dimensions

The max overall dimensions are shown in figure 2.

3.2. Set the sensor to work

The assembly and set to work of the instrument are carried out by three simple steps that allow a quick and precise installation:

1. INSTALLATION OF THE SENSOR ON THE WET-TAP CLAMP SADDLE
2. MEASUREMENT OF THE WALL THICKNESS OF THE PIPE
3. VERTICAL POSITIONING OF THE SENSOR INTO THE PIPE

Warning: the FLS 111 allows installation into pressurised pipes without system shutdown; we recommend to pay maximum attention when screwing the clamping bolts of the measuring rod. The rod is pushed upwards by the internal pressure

Note: lubricate the steel rod to reduce frictions with the O-rings. This will help the installation, measurement and positioning operations.

1. INSTALLATION OF THE SENSOR ON THE WET-TAP CLAMP SADDLE

Warning: these installations steps can be applied to every wet-tap clamp saddle with the following properties:

- Branch minimum diameter : 46mm (1.8 in.)
- Branch thread : 2" GAS (cylindrical)
- $A_{min.} = 44 \text{ mm (1,7 in.)}$ (figure 1)

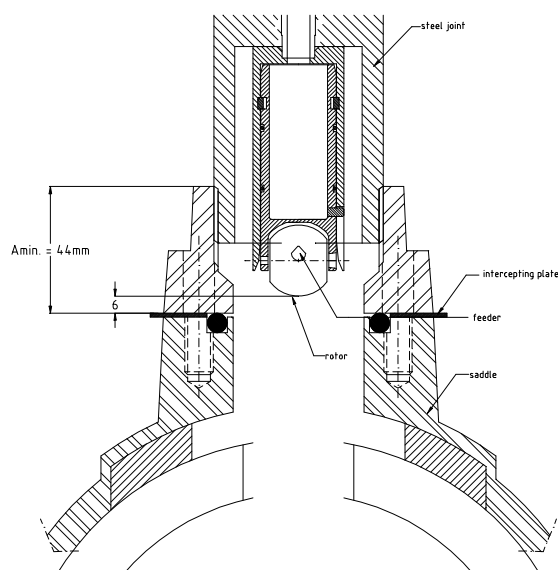
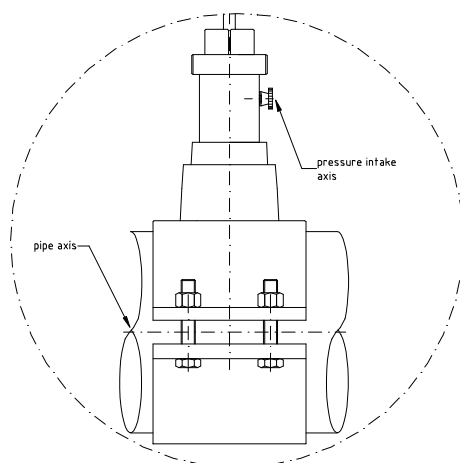

Figure 1

- a) Assemble the saddle in the desired position to install the sensor.
Drill the pipe. Use a 40 mm (1.6 in.) milling cutter.
Remove the drilling machine. Be careful to block the fluid using the proper intercepting plate or ball valve.
- b) Wrap several turns of Teflon tape around the steel joint threads to prevent leaks. Screw the steel joint, together with the measuring rod and the sensor, in the saddle branch.
Be careful to set the AXIS of the PRESSURE INTAKE PARALLEL to the AXIS of the



PIPE.

- c) Remove the intercepting plate or open the ball valve to the full open position (perpendicular to pipe).

2. MEASUREMENT OF THE WALL THICKNESS OF THE PIPE (patented system)

- a) Rotate the rod to get the reference screw on the top in the same direction of the pressure intake. Gently insert the sensor into the pipe until the feeder is roughly in the centre of the pipe.

The feeder is in the same direction of the reference screw.

Note: Be careful not to insert the rod too much downwards: the sensor rotor could bump against the pipe wall.

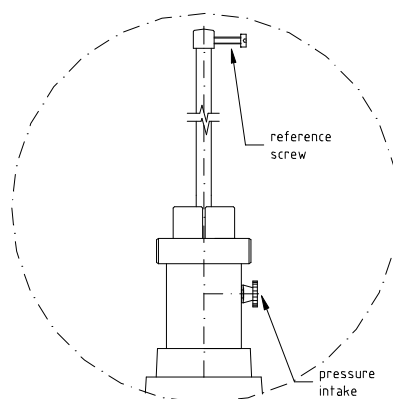

- b) Rotate the rod 180° degrees and follow its natural upwards movement till it stops. The feeder is touching the internal diameter of the pipe and the reference screw is now in the opposite direction of the pressure intake.

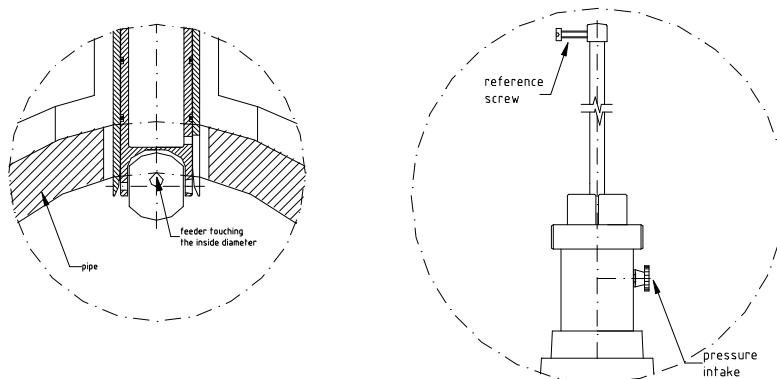

- c) Get the sliding bush to be in contact with the pin and screw the fixing knob; be careful not to damage the rod.

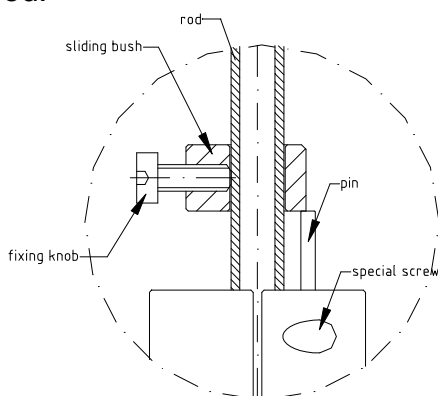

- d) Rotate the rod 180° degrees to free the feeder from the internal diameter of the pipe and, at the same time, follow its natural upwards movement.

- e) Rotate again the rod 180° degrees and push it downwards to get the feeder touching the external diameter of the pipe. Fix the sensor in this position tightening the special screws.

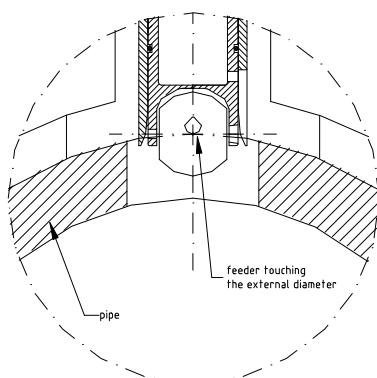

- f) Use a sliding gauge to measure the distance between the top of the pin and the bottom side of the sliding bush.

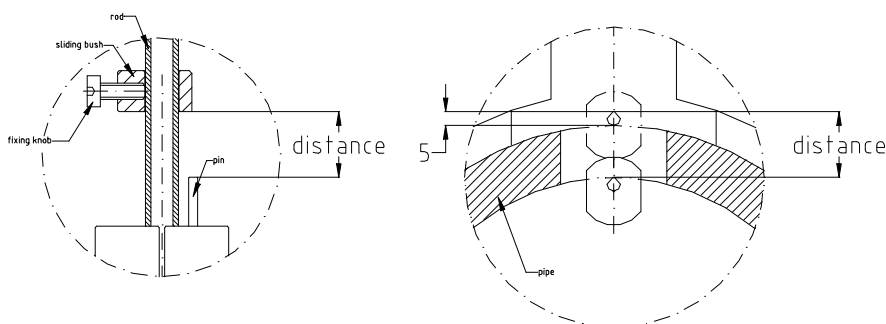

- g) Subtract “5 mm” to the measured distance: the value obtained is the wall thickness of the pipe.

3. VERTICAL POSITIONING OF THE SENSOR INTO THE PIPE

- a) Position the sensor in order to have the feeder touching the internal diameter of the pipe and fix the rod with the special screws. Be careful to set the reference screw

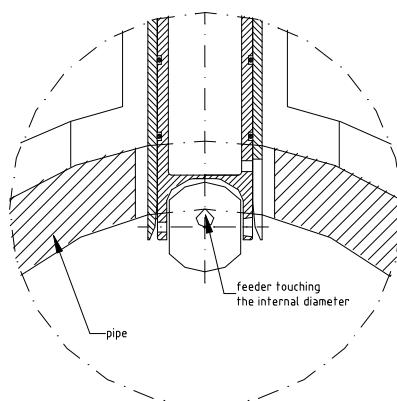

PARALLEL to the axis of the pipe.

- b) Get the sliding bush to be in contact with the pin and screw the fixing knob.

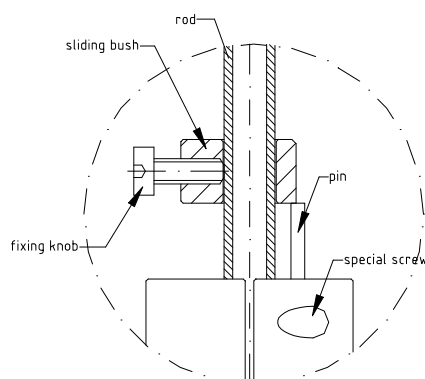

c) Calculate the INTERNAL DIAMETER (ID) of the pipe:

$$ID = D - 2 \times W_T$$

D = EXTERNAL DIAMETER

W_T = WALL THICKNESS

NOTE: measure the CIRCUMFERENCE of the pipe if the EXTERNAL DIAMETER is unknown:

$$\text{EXTERNAL DIAMETER} = \text{CIRCUMFERENCE} / 3.14$$

d) Move and fix the sliding bush at a distance from the pin equals to:

$$\text{DISTANCE (mm)} = [0.12 \times \text{INTERNAL DIAMETER}](\text{mm}) - 5(\text{mm})$$

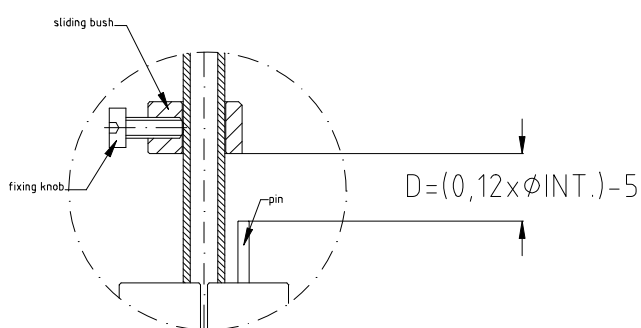

e) Turn the special screws out and push the rod downwards to get the sliding bush being in contact with the pin. Make sure the reference screw on the top of the rod is

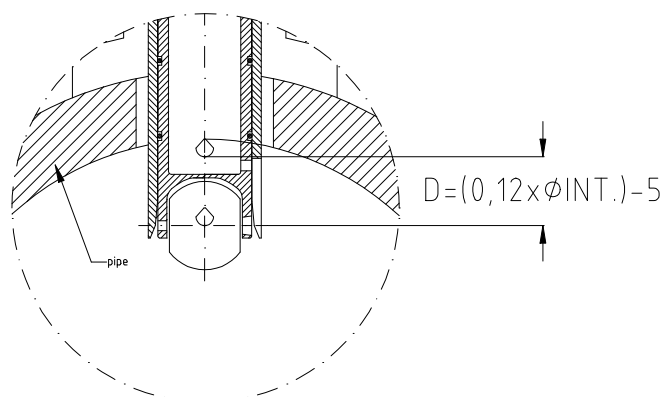

PARALLEL to the axis of the pipe and fix again the sensor tightening the special screws.

The sensor is now ready to measure.

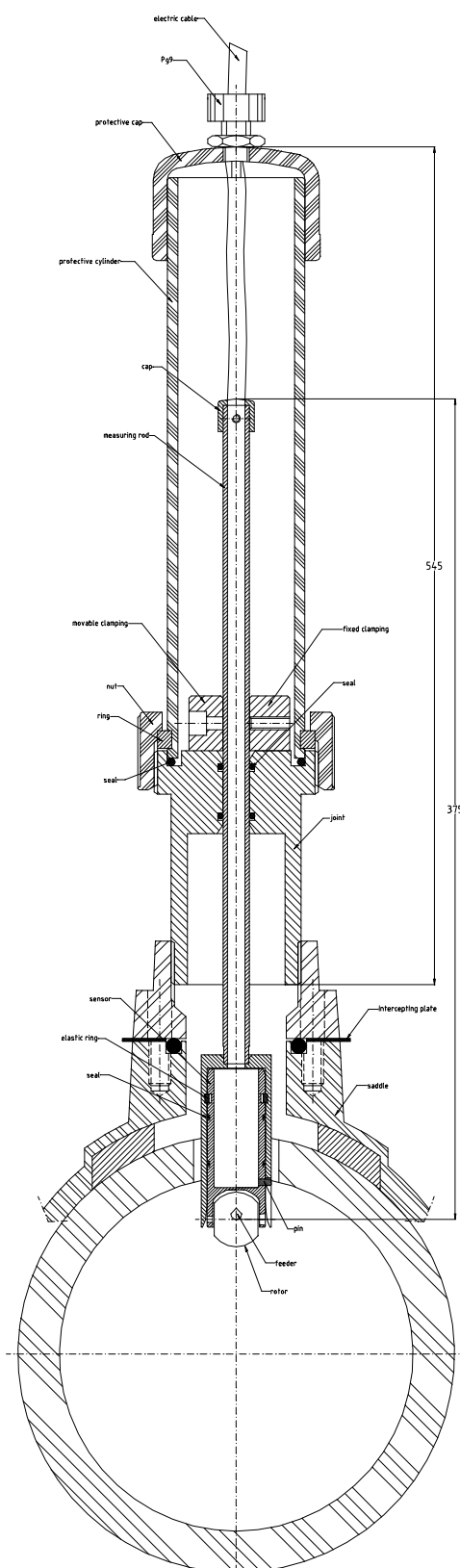

Figure 2

4. K-Factor Tables

DN range (mm)	K-Factor	DN range (mm)	K-Factor	DN range (mm)	K-Factor
65 - 67	15,81	111 - 113	4,68	157 - 159	2,21
67 - 69	14,89	113 - 115	4,51	159 - 161	2,16
69 - 71	14,05	115 - 117	4,36	161 - 163	2,10
71 - 73	13,28	117 - 119	4,21	163 - 165	2,05
73 - 75	12,57	119 - 121	3,99	165 - 167	2,00
75 - 77	11,32	121 - 123	3,86	167 - 169	1,96
77 - 79	10,75	123 - 125	3,74	169 - 171	1,91
79 - 81	10,22	125 - 127	3,62	171 - 173	1,83
81 - 83	9,73	127 - 129	3,51	173 - 175	1,79
83 - 85	9,27	129 - 131	3,40	175 - 177	1,75
85 - 87	8,84	131 - 133	3,30	177 - 179	1,71
87 - 89	8,44	133 - 135	3,20	179 - 181	1,67
89 - 91	8,07	135 - 137	3,11	181 - 183	1,63
91 - 93	7,07	137 - 139	3,02	183 - 185	1,60
93 - 95	6,78	139 - 141	2,88	185 - 187	1,56
95 - 97	6,50	141 - 143	2,79	187 - 189	1,53
97 - 99	6,23	143 - 145	2,72	189 - 191	1,50
99 - 101	5,99	145 - 147	2,64	191 - 193	1,44
101 - 103	5,75	147 - 149	2,57	193 - 195	1,41
103 - 105	5,53	149 - 151	2,50	195 - 197	1,38
105 - 107	5,22	151 - 153	2,44	197 - 199	1,35
107 - 109	5,03	153 - 155	2,38	199 - 201	1,33
109 - 111	4,85	155 - 157	2,32	201 - 203	1,30

NOTE: The K-Factor values can depend upon the installation conditions.

F.I.P. Formatura Iniezione Polimeri S.p.A.
 Loc. Pian di Parata, 16015 Casella (GE) – Italy
 Tel +39 010 96211 – Fax +39 010 9621209

www.flisnet.it